

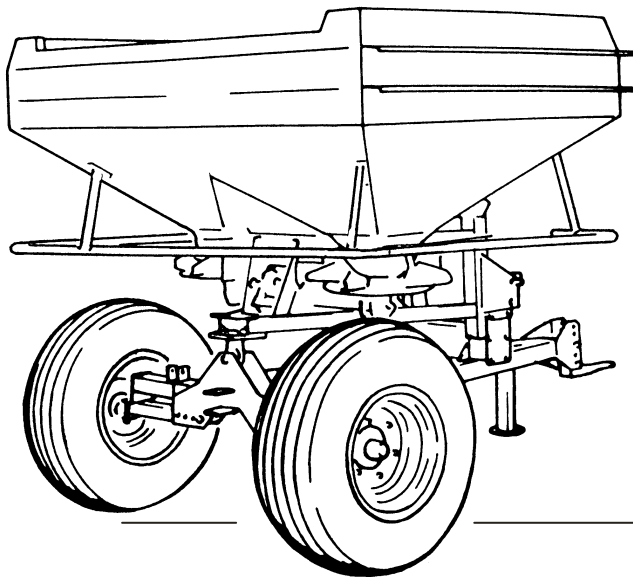

**ONDERDELENLIJST
PARTS LIST
LISTE DE PIECES DE RECHANGE
ERSATZTEILLISTE**

**CARRIER
WHEELED CARRIER
CHARIOT DE TRANSPORT
FAHRGESTEL**



CENTERLINER S/SL - SE

CENTERLINER	type nummer type number numéro de type Typennummer	vanaf serienummer as from serial number après numéro serie ab Seriennummer
	2.3218.2111.1	1000 - 0501
	2.3218.2115.1	10511 - 0501



ONDERDELEN

Bij het bestellen van onderdelen is het belangrijk dat u het type- en serienummer van uw machine opgeeft. Gebruik alleen originele LELY-onderdelen.

SPARE PARTS

When ordering spare parts, it is important that you indicate the type and serial number of your machine.

Use only genuine LELY parts.

PIECES DE RECHANGE

En commandant des pièces de rechange il importe que vous indiquiez les numéros de type et de série de votre machine.

N'utiliser que des pièces d'origines LELY.

ERSATZTEILE

Beim Bestellen von Ersatzteilen ist es wichtig, daß Sie die Typ- und Seriennummer Ihrer Maschine angeben.

Nur Original-LELY-Ersatzteile verwenden.

Typ- und Seriennummer in nebenstehende Abbildung eintragen. Bei künftigen Bestellungen haben Sie die Nummer dann griffbereit.

Vul het type- en serienummer hieronder in.

Bij toekomstige onderdelenbestellingen heeft u de nummers dan bij de hand.

Complete the box below with the type and serial number.

This is an easy reference with a view to future spare parts ordering.

Veillez noter, ci-dessous, les numéros de type et de serie.

Ceci est important pour toutes commandes de pièces de rechange.

LELY		LELY INDUSTRIES NV		CE
		3147 PA MAASSLUIS THE NETHERLANDS		
		kg		
Type				
Ser.Nr.				

Verklaring van de in de onderdelenlijst gebruikte tekens.

Explanation of signs used in the parts list.

Explication des signes qui figurent dans la liste des pièces.

Erklärung der in der Ersatzteilliste verwendeten Zeichen.

[R] = RECHTSE UITVOERING
RH VERSION

[L] = LINKSE UITVOERING
LH VERSION

Onder rechtse of linkse uitvoering wordt de plaats van het onderdeel verstaan, gezien van de achterzijde van de machine.

By RH or LH version the position of the part is meant, seen from the rear of the machine

[RD] = RECHTSOM DRAAIENDE UITVOERING
RH ROTATING VERSION

[LD] = LINKSOM DRAAIENDE UITVOERING
LH ROTATING VERSION

Onder rechtson of linksom draaiende uitvoering wordt de draairichting van het onderdeel verstaan, gezien van de bovenzijde van de machine.

By RH or LH rotating version the sense of rotating of the part is meant, seen from the top of the machine.

[x] = ONDERDEEL WORDT NIET GETOOND
PART IS NOT SHOWN

Bijvoorbeeld linkse uitvoering overeenkomstig de wel getekende rechtse uitvoering.

E.g. : LH version is similar to the RH version, which is actually shown.

[#] = NIET LOS LEVERBAAR
NOT AVAILABLE SEPARATELY

~ = AANTAL (INDIEN NODIG) AFHANKELIJK VAN INBOUWMAAT
QUANTITY (IF APPLICABLE) DEPENDING UPON ASSEMBLY

[—] = SLUITRING

[—/—] = VEERRING

[####] = TANDVEERRING

[x]◀ = OLIEKEERRING

[T+T] = TANDWIELSET

[D+D] = VULRINGSET

[A+A] = SET AFDICHTINGSRINGEN

WASHER

SPRING WASHER

SHAKE-PROOF WASHER

OIL SEAL

PAIR OF GEARS

SHIM SET

SET OF SEALING RINGS

VERSION DROITE
RECHTE AUSFÜHRUNG

VERSION GAUCHE
LINKE AUSFÜHRUNG

Par version droite ou gauche on entend la position de la pièce, vue de l'arrière de la machine.

Die Verweisungen "rechte Ausführung" oder "linke Ausführung" geben die Position des Teils, von der Hinterseite der Maschine aus gesehen, an.

VERSION ROTATION A DROITE
RECHTSUMDREHENDE AUSFÜHRUNG

VERSION ROTATION A GAUCHE
LINKSUMDREHENDE AUSFÜHRUNG

Version rotation à droit: ceci correspond au sens de rotation de la pièce, vue du dessus la machine.

Mit diesen Verweisungen wird die Drehrichtung des Teils von der Oberseite der Maschine aus gesehen, angegeben.

PIECE N'EST PAS MONTREE
TEIL WIRD NICHT GEZEIGT

Exemple : la version gauche est représentée. La version droite correspond à la version gauche, mais n'est pas représentée.

Beispiel : die linke Ausführung entspricht der effektiv gezeigten Rechten.

VENDU EN KIT UNIQUEMENT
NICHT SEPARAT LIEFERBAR

QUANTITE (SI NÉCESSAIRE) EN FONCTION DU MONTAGE
ANZAHL VOM EINBAUMASS ABHÄNGIG (WENN ERFORDERLICH)

RONDELLE PLATE

RONDELLE GROWER

RONDELLE EVENTAIL

ETANCHEITE

JEU D'ENGRENAGES

JEU D'ÉPAISSEURS

JEU D'ANNEAUX D'ETANCHEITE

UNTERLEGSCHIEBE

FEDERRING

RÄNDELFEEDRING

ÖLDICHTUNGSRING

ZAHNRÄDERSATZ

PASSSCHEIBENSATZ

DICHTUNGSRINGENSATZ



Inhoud
Contents
Index
Inhalt

CARRIER
WHEELED CARRIER
CHARIOT DE TRANSPORT
FAHRGESTELL

pagina
page
page
Seite

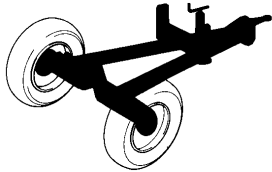

Carrier + ashelft
Wheeled carrier + shaft half
Chariot de transport + demi-arbre
Fahrgestell + Wellenhälfte

01

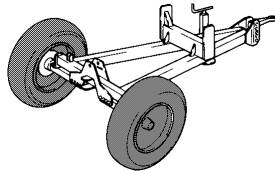

Velg + luchtband
Rim + pneumatic tyre
Jante + pneumatique
Felge + Luftreifen

S/SL

02

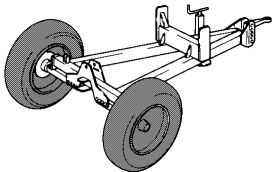

Velg + luchtband
Rim + pneumatic tyre
Jante + pneumatique
Felge + Luftreifen

SE

03

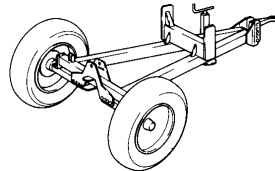

Bedieningskabel
Control cable
Câble de commande
Bedienungskabel

S/SL/SE

02/03

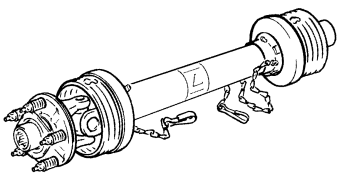

Koppelingsas
PTO shaft
Arbre de transmission
Gelenkwelle

04

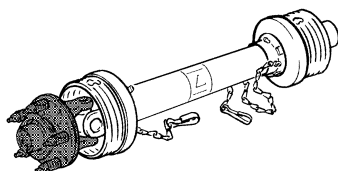

Slipkoppeling
Friction clutch
Limiteur à friction
Reibkupplung

05

Verplichte beschermbeugel: zie onderdelenlijst kunstmeststrooiers

Mandatory protection bracket: see parts list fertilizerspreaders

Arceau protecteur obligatoire: reportez-vous à la liste de pièces de rechange des épandeurs d'engrais

Vorgeschriebener Schutzbügel: siehe Ersatzteilliste Düngerstreuer

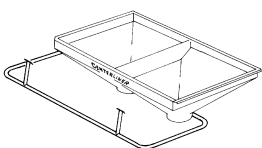

LELY

CENTERLINER	type number type number numéro de type Typnummer	vanaf serienummer as from serial number après numéro de série ab Seriennummer
S/SL-SE	2.3218.2111.1	1000 - 0501
S/SL-SE	2.3218.2115.1	10511 - 0501

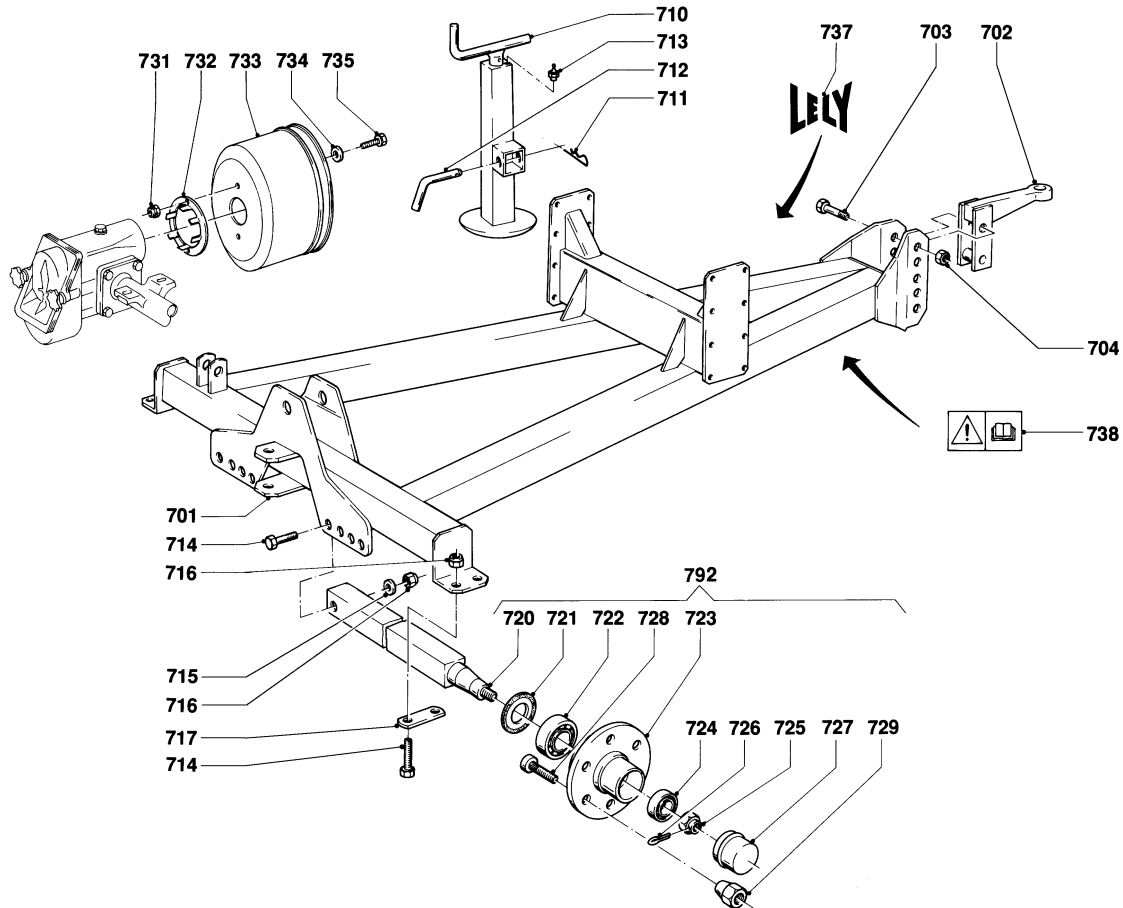
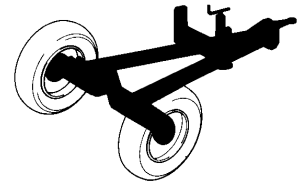

A033-03-01

REF.	ONDERDEELNR. PART NUMBER REFERENCE TEILNUMMER	AANTAL QUANTITY QUANTITE ANZAHL	
701	2.3218.2121.0	1	
702	2.3215.2110.0	1	
703	9.1113.0474.1	2	M20x120 DIN 931-A2-2
704	9.1030.0043.6	2	M20 DIN 985-A2-2
710	2.3218.2151.0	1	
711	9.1124.0005*0	1	Ø6
712	1.1624.1490.0	1	
713	9.1069.0001*2	1	H 1A 6
714	9.1113.0473.0	6	M16x100 DIN 931-A2-2
715	9.1048.0085.2	2	A17 DIN 125-A2
716	9.1030.0034.4	6	M16 DIN 985-A2
717	2.3218.2165.0	2	
720	#	1+1	
721	#	1+1	Ø50 x Ø90
722	9.1002.0026.3	1+1	30210
723	#	1+1	
724	9.1002.0002.0	1+1	30207
725	9.1031.0011.1	1+1	M30x1,5 DIN 937-06
726	9.1072.0007.5	1+1	5x45 DIN 94
727	9.1041.0103.6	1+1	72 mm
728	9.1114.0503.4	6+6	M18x1,5 - 8.8
729	9.1036.0020.5	6+6	M18x1,5

REF.	ONDERDEELNR. PART NUMBER REFERENCE TEILNUMMER	AANTAL QUANTITY QUANTITE ANZAHL	
731	9.1030.0022.6	2	M10 DIN 985-A2-2
732	2.3215.1487.0	1	
733	1.1636.1049.0	1	
734	9.1048.0062*0	2	A10,5 DIN 7349 [—]
735	9.1113.0170.1	2	M10x25 DIN 933-A2-2
737	9.1170.0003.1	1	
738	9.1170.0408.0	1	
792	2.3218.2169.0	2	= REF. 720-729

LELY

CENTERLINER	type number type number numéro de type Typnummer	vanaf serienummer as from serial number après numéro de série ab Seriennummer
S/SL	2.3218.2111.1	1000 - 0501
S/SL	2.3218.2115.1	10511 - 0501

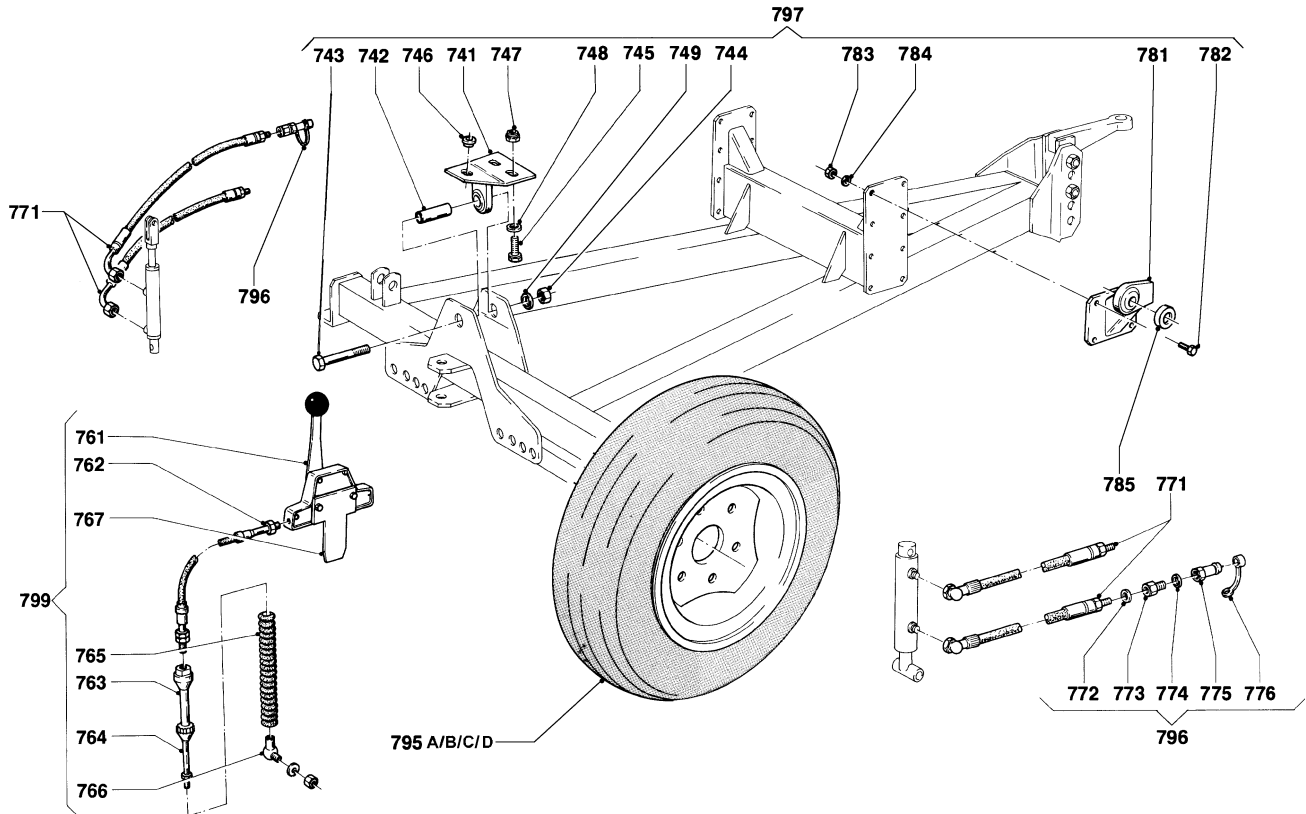
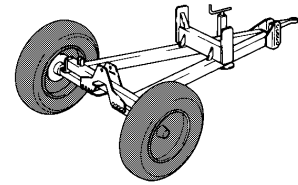

A038-02-10

REF.	ONDERDEELNR. PART NUMBER REFERENCE TEILNUMMER	AANTAL QUANTITY QUANTITE ANZAHL	
741	2.3218.2290.0	1	
742	2.3218.2319.0	1	
743	9.1113.0471.5	1	M20x150 DIN 931-A2-2
744	9.1029.0049.4	1	M20 DIN 934-A2
745	9.1113.0339.1	3	M16x55 DIN 931-A2-2
746	2.3218.2318.0	1	[—]
747	9.1030.0034.4	3	M16 DIN 985-A2-2
748	9.1048.0085.2	3	A17 DIN 125-A2 [—]
749	9.1121.0027.4	1	A20 DIN 127-A2 [—]
761	9.1180.0806.3	1	
762	9.1180.0811.1	1	M6 L= 3800 mm
763	9.1180.0803.0	1	
764	9.1180.0812.2	1	M6 L= 3800 mm
765	9.1180.0802.6	1	
766	9.1180.0801.5	1	M6
767	9.1180.0807.4	1	
771	4.1016.2120.0	2+2	L= 3050 mm
772	9.1137.0409.6	2+2	Ø13,74x20,57x2,03 [—]
773	9.1137.0603.4	2+2	1/2"-1/4"
774	9.1137.0411.1	2+2	Ø21,54x28,58x2,34 [—]
775	9.1137.0302.4	2+2	1/2" G
776	9.1137.0303.5	2+2	1/2" PVC

REF.	ONDERDEELNR. PART NUMBER REFERENCE TEILNUMMER	AANTAL QUANTITY QUANTITE ANZAHL	
781	2.3218.2260.0	1	[R]
	2.3218.2250.0	1	[L][x]
782	9.1113.0337.6	8	M12x40 DIN 933-A2-2
783	9.1030.0023.0	8	M12 DIN 985-A2-2
784	9.1048.0080.4	8	A13 DIN 125-A2 [—]
785	2.3225.2167.0	2	
795 A	9.1175.0012.5	(2)	Ø890 x 350 mm / 1 bar [x]
795 B	9.1175.0020.6	(2)	Ø792 x 368 mm / 1.4 bar [x]
795 C	9.1175.0021.0	2	Ø760 x 270 mm / 2.25 bar
795 D	9.1175.0018.4	(2)	Ø875 x 400 mm / 2 bar [x]
796	2.3201.2312.8	2(+2)	= REF. 772-776
797	2.3218.2271.0	1	= REF. (741-749)+(781-784)
799	9.1180.0810.0	1	= REF. 761-767 L= 3800 mm

LELY

CENTERLINER	type number type number numéro de type Typnummer	vanaf serienummer as from serial number après numéro de série ab Seriennummer
SE	2.3218.2111.1	1000 - 0501
SE	2.3218.2115.1	10511 - 0501

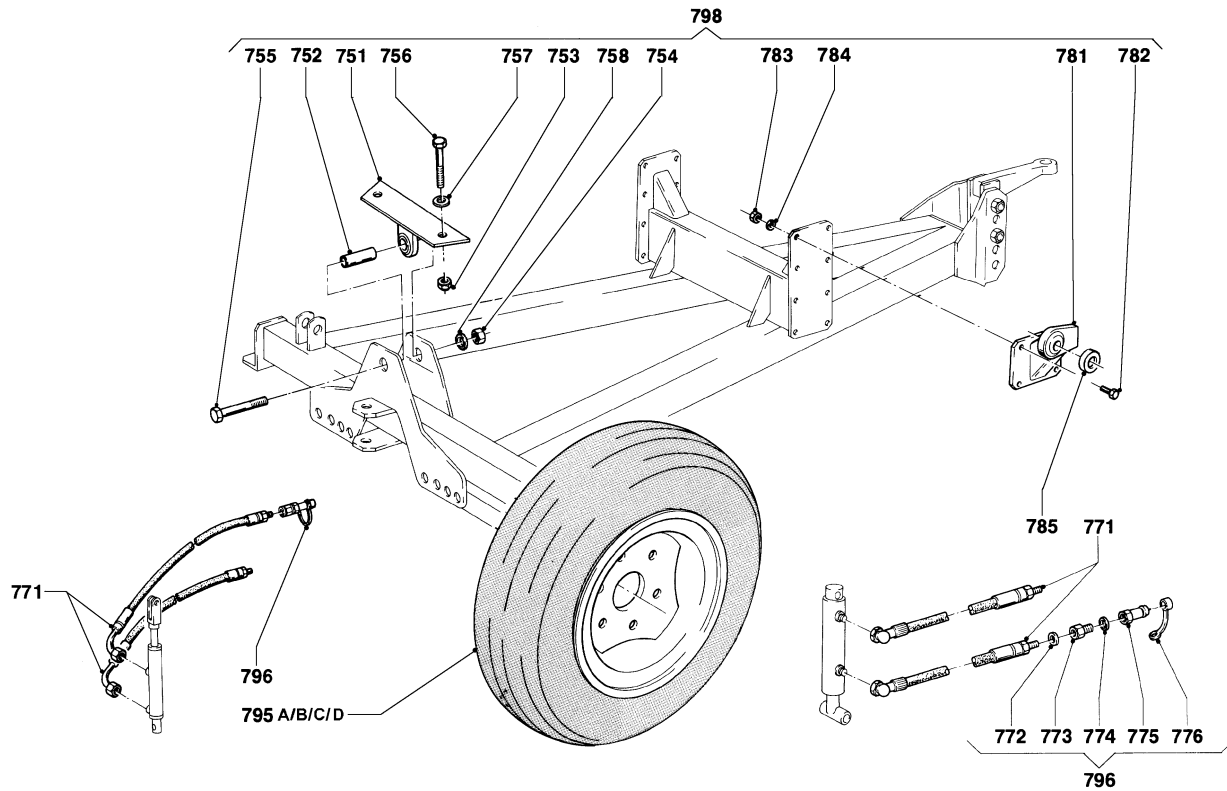
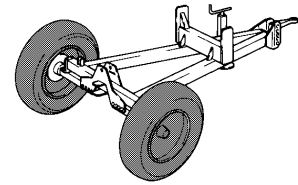

A38-02-20

REF.	ONDERDEELNR. PART NUMBER REFERENCE TEILNUMMER	AANTAL QUANTITY QUANTITE ANZAHL	
------	--	--	--

751	2.3226.1261.0	1	
752	2.3218.2319.0	1	
753	9.1030.0034.4	2	M16 DIN 985-A2-2
754	9.1029.0049.4	1	M20 DIN 934-A2-2
755	9.1113.0471.5	1	M20x160 DIN 931-A2-2
756	9.1113.0473.0	2	M16x100 DIN 931-A2-2
757	9.1048.0096.6	2	17 DIN 7349-A2 [—]
758	9.1127.0027.4	1	A20 DIN 127-A2 [—]

771	4.1016.2120.0	2+2	L= 3050 mm
772	9.1137.0409.6	2+2	Ø13,74x20,57x2,03 [—]
773	9.1137.0603.4	2+2	1/2"-1/4"
774	9.1137.0411.1	2+2	Ø21,54x28,58x2,34 [—]
775	9.1137.0302.4	2+2	1/2" G
776	9.1137.0303.5	2+2	1/2" PVC

781	2.3218.2260.0	1	[R]
	2.3218.2250.0	1	[L][x]
782	9.1113.0337.6	8	M12x40 DIN 933-A2-2
783	9.1030.0023.0	8	M12 DIN 985-A2-2
784	9.1048.0080.4	8	A13 DIN 125-A2 [—]
785	2.3225.2167.0	2	

REF.	ONDERDEELNR. PART NUMBER REFERENCE TEILNUMMER	AANTAL QUANTITY QUANTITE ANZAHL	
------	--	--	--

795 A	9.1175.0012.5	(2)	Ø890 x 350 mm / 1 bar [x]
795 B	9.1175.0020.6	(2)	Ø792 x 368 mm / 1.4 bar [x]
795 C	9.1175.0021.0	2	Ø760 x 270 mm / 2.25 bar
795 D	9.1175.0018.4	(2)	Ø875 x 400 mm / 2 bar [x]

796 2.3201.2312.8 2(+2) = REF. 772-776

798 2.3226.1252.0 1 = REF. (751-758)+(781-784)

LELY

CENTERLINER	type number type number numéro de type Typnummer	vanaf serienummer as from serial number après numéro de série ab Seriennummer
S/SL-SE	2.3218.2111.1	1000 - 0501
S/SL-SE	2.3218.2115.1	10511 - 0501

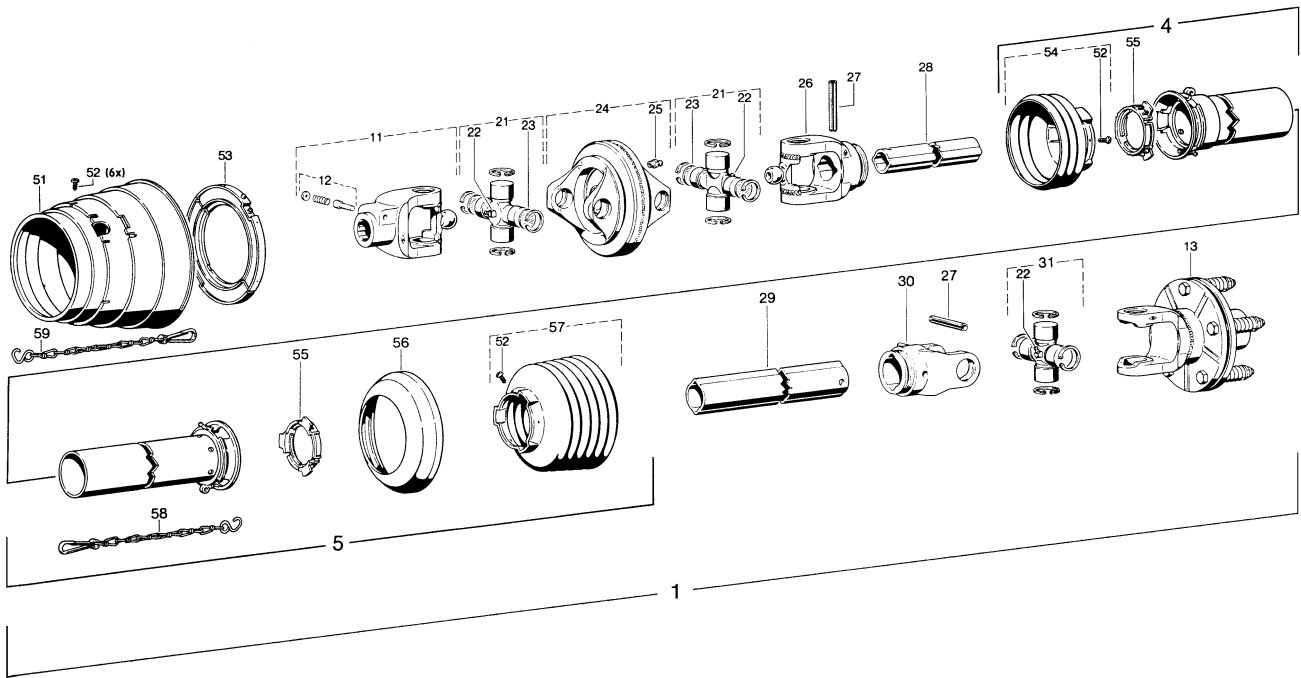
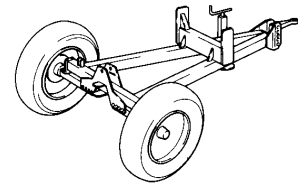

Aw005-03-01

REF.	ONDERDEELNR. PART NUMBER REFERENCE TEILNUMMER	AANTAL QUANTITY QUANTITE ANZAHL	
------	--	--	--

1	9.1154.0118.6	1	WWE2280-SD15-1410-K94/1 = REF. 11-59
4	85.102	1	SCH15-A1300-RP2
5	85.104	1	SCH15-J1300-RP6-K
11	20.10.810	1	1.3/8" (6)
12	33.91.07	1	AGRASET 101
13	56.115.19	1	K94/1- 1.1/8" (6); M= 400Nm.
21	20.06.00	2	Cpl.
22	63.27.00	3	BM8x1
23	20.06.70	4	21,95x2
24	+20.91.05	1	
25	63.12.01	1	AM8x1
26	20.11.810	1	RG2280-Ov
27	61.05.04	2	10x65 DIN 1481
28	75.11.96	1	OvGA-1220
29	75.16.16	1	1G-1210
30	20.12.00	1	RG2200-1
31	20.00.00	1	Cpl.

REF.	ONDERDEELNR. PART NUMBER REFERENCE TEILNUMMER	AANTAL QUANTITY QUANTITE ANZAHL	
------	--	--	--

51	85.00.00	1	
52	60.15.00	8	4x10
53	82.83.12	1	
54	85.14.106	1	n= 2
55	82.83.06	2	
56	82.85.00	1	
57	85.15.05	1	n= 5
58	82.36.03	1	400
59	82.36.08	1	600

LELY

CENTERLINER	type number type number numéro de type Typnummer	vanaf serienummer as from serial number après numéro de série ab Seriennummer
S/SL-SE	2.3218.2111.1	952 - 0525
S/SL-SE	2.3218.2115.1	10511 - 0501

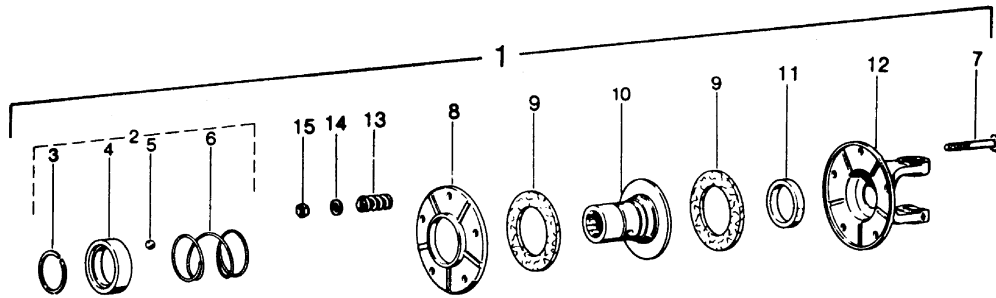
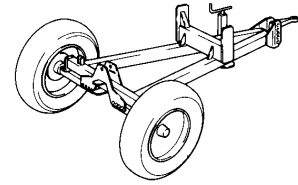

Aw002-03-00

REF.	ONDERDEELNR. PART NUMBER REFERENCE TEILNUMMER	AANTAL QUANTITY QUANTITE ANZAHL	
1	56.115.19	(1)	K94/1-2200 1.1/8" (6); 400 Nm = REF. 3-15
2	19.36.58	1	AGRASET 140 = REF. 3-6
3	62.07.04	1	SW43
4	16.50.493	1	43x58
5	64.01.00	3	3/8"-5 DIN 5401
6	66.01.55	1	
7	9.1113.0175*6	5	M8x60 DIN 931
8	16.20.69	1	
9	56.73.13	2	56x90
10	16.50.494	1	1.1/8" (6)
11	16.52.05	1	43x53
12	20.15.179	1	K94/1-2200
13	66.01.47	5	
14	9.1048.0004*5	5	B8,4 DIN 125 [—]
15	9.1030.0012*3	5	M8 DIN 985

REF.	ONDERDEELNR. PART NUMBER REFERENCE TEILNUMMER	AANTAL QUANTITY QUANTITE ANZAHL
------	--	--