

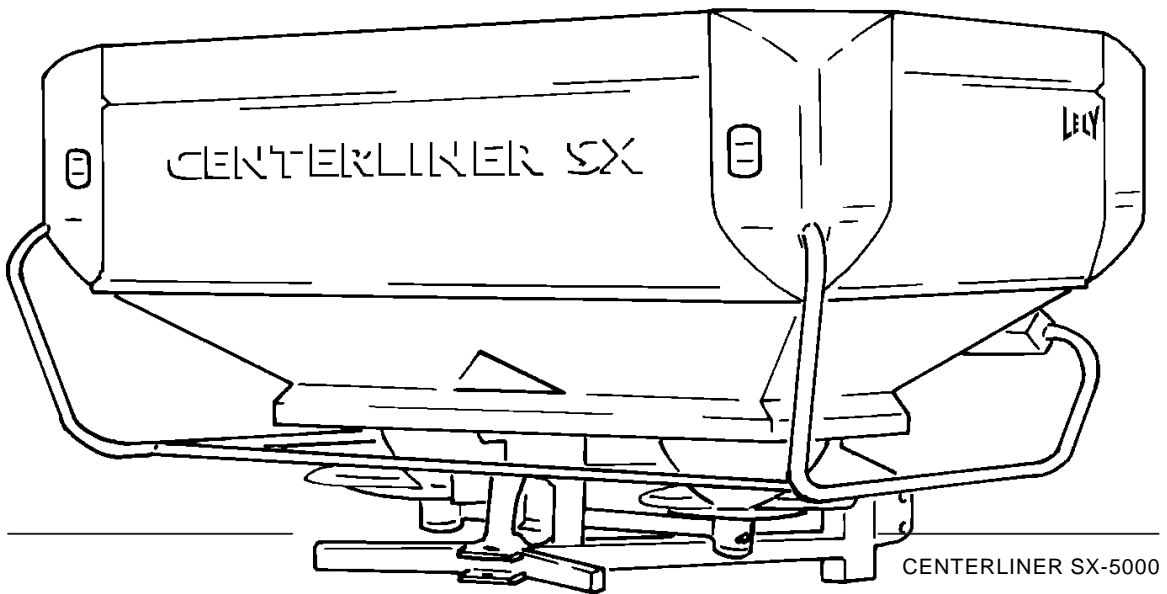

**ONDERDELENLIJST  
PARTS LIST  
LISTE DE PIECES DE RECHANGE  
ERSATZTEILLISTE**

# CENTERLINER SX



CENTERLINER	type number type number numéro de type Typennummer	vanaf serienummer as from serial number après numéro série ab Seriennummer
SX	2.3227.0001.1	10510 - 0501



## ONDERDELEN

Bij het bestellen van onderdelen is het belangrijk dat u het type- en serienummer van uw machine opgeeft. Gebruik alleen originele LELY-onderdelen.

## SPARE PARTS

When ordering spare parts, it is important that you indicate the type and serial number of your machine. Use only genuine LELY parts.

## PIECES DE RECHANGE

En commandant des pièces de rechange il importe que vous indiquiez les numéros de type et de série de votre machine. N'utiliser que des pièces d'origines LELY.

## ERSATZTEILE

Beim Bestellen von Ersatzteilen ist es wichtig, daß Sie die Typ- und Seriennummer Ihrer Maschine angeben.

Nur Original-LELY-Ersatzteile verwenden.

Typ- und Seriennummer in nebenstehende Abbildung eintragen. Bei künftigen Bestellungen haben Sie die

Vul het type- en serienummer hieronder in.

Bij toekomstige onderdelenbestellingen heeft u de nummers dan bij de hand.

Complete the box below with the type and serial number.

This is an easy reference with a view to future spare parts ordering.

Veillez noter, ci-dessous, les numéros de type et de serie.

Ceci est important pour toutes commandes de pièces de rechange.

<b>LELY</b>	LELY INDUSTRIES NV 3147 PA MAASSLUIS THE NETHERLANDS		<b>CE</b>
		kg	
Type			
Ser.Nr.			

Verklaring van de in de onderdelenlijst gebruikte tekens.  
Explanation of signs used in the parts list.

Explication des signes qui figurent dans la liste des pièces.  
Erklärung der in der Ersatzteilliste verwendeten Zeichen.



[R]	= RECHTSE UITVOERING RH VERSION	VERSION DROITE RECHTE AUSFÜHRUNG		
[L]	= LINKSE UITVOERING LH VERSION  Onder rechtse of linkse uitvoering wordt de plaats van het onderdeel verstaan, gezien van de achterzijde van de machine. By RH or LH version the position of the part is meant, seen from the rear of the machine	VERSION GAUCHE LINKE AUSFÜHRUNG  Par version droite ou gauche on entend la position de la pièce, vue de l'arrière de la machine. Die Verweisungen "rechte Ausführung" oder "linke Ausführung" geben die Position des Teils, von der Hinterseite der Maschine aus gesehen, an.		
[RD]	= RECHTSOM DRAAIENDE UITVOERING RH ROTATING VERSION	VERSION ROTATION A DROITE RECHTSUMDREHENDE AUSFÜHRUNG		
[LD]	= LINKSOM DRAAIENDE UITVOERING LH ROTATING VERSION  Onder rechtsom of linksom draaiende uitvoering wordt de draairichting van het onderdeel verstaan, gezien van de bovenzijde van de machine. By RH or LH rotating version the sense of rotating of the part is meant, seen from the top of the machine.	VERSION ROTATION A GAUCHE LINKSUMDREHENDE AUSFÜHRUNG  Version rotation à droit: ceci correspond au sens de rotation de la pièce, vue du dessus la machine. Mit diesen Verweisungen wird die Drehrichtung des Teils von der Oberseite der Maschine aus gesehen, angegeben.		
[x]	= ONDERDEEL WORDT NIET GETOOND PART IS NOT SHOWN  Bijvoorbeeld linkse uitvoering overeenkomstig de wel getekende rechtse uitvoering. E.g. : LH version is similar to the RH version, which is actually shown.	PIECE N'EST PAS MONTREE TEIL WIRD NICHT GEZEIGT  Exemple : la version gauche est représentée. La version droite correspond à la version gauche, mais n'est pas représentée. Beispiel : die linke Ausführung entspricht der effectiv gezeigten Rechten.		
[#]	= NIET LOS LEVERBAAR NOT AVAILABLE SEPARATELY	VENDU EN KIT UNIQUEMENT NICHT SEPARAT LIEFERBAR		
~	= AANTAL (INDIEN NODIG) AFHANKELIJK VAN INBOUWMAAT QUANTITY (IF APPLICABLE) DEPENDING UPON ASSEMBLY	QUANTITE (SI NÉCESSAIRE) EN FONCTION DU MONTAGE ANZAHL VOM EINBAUMASS ABHÄNGIG (WENN ERFORDERLICH)		
[—]	= SLUITRING	WASHER	RONDELLE PLATE	UNTERLEGSCHIEBE
[—/—]	= VEERRING	SPRING WASHER	RONDELLE GROWER	FEDERRING
[###]	= TANDVEERRING	SHAKE-PROOF WASHER	RONDELLE EVENTAIL	RÄNDELFEDEERING
[* *]	= OLIEKEERRING	OIL SEAL	ETANCHEITE	ÖLDICHTUNGSRING
[T+T]	= TANDWIELSET	PAIR OF GEARS	JEU D'ENGRENAGES	ZAHNRÄDERSATZ
[D+D]	= VULRINGSET	SHIM SET	JEU D'ÉPAISSEURS	PASSSCHEIBENSATZ
[A+A]	= SET AFDICHTINGSRINGEN	SET OF SEALING RINGS	JEU D'ANNEAUX D'ETANCHEITE	DICHTUNGSRINGENSATZ



Inhoud  
Contents  
Index  
Inhalt

## CENTERLINER SX

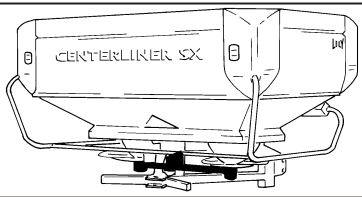
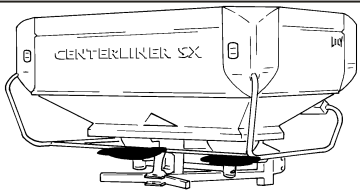
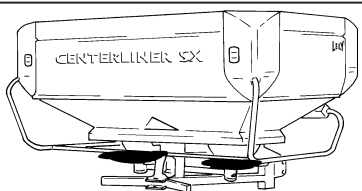
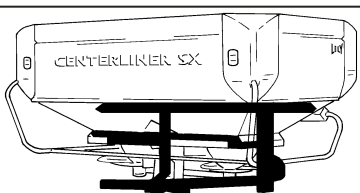
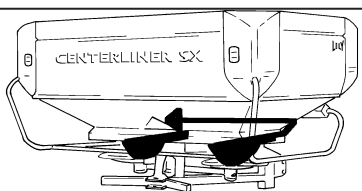
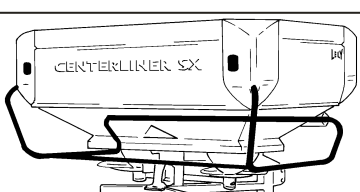
pagina  
page  
page  
Seite

	Aandrijving Transmission Entraînement Antrieb	01	
	Werp­schijven Ejector disks Disques éjecteurs Wurfscheiben	(Korte schoep) (Short spoon) (Aube courte) (Kurzer Leitschaufel)	02
	Werp­schijven Ejector disks Disques éjecteurs Wurfscheiben	(Lange schoep) (Long spoon) (Aube longue) (Langer Leitschaufel)	03
	Freem + kantelcilinder Frame + tilt ram Châssis + vérin d'inclinaison Rahmen + Zylinder zur Schrenkstellung		04
	Dosering Feed system Ensemble de dosage Dosiervorrichtung		05
	Verlichting + Beschermbeugel Lighting + Protection bracket Éclairage + Arceau de protection Beleuchtung + Schutzbügel		06
	Hydraulische bediening Hydraulic command Commande hydraulique Hydraulische Bedienung		07
	Vorraadbak + Opzetrand Hopper + Hopper extension Trémie + Rehausse de trémie Behälter + Behälteraufsatz		08



Inhoud  
Contents  
Index  
Inhalt

## CENTERLINER SX

pagina  
page  
page  
Seite

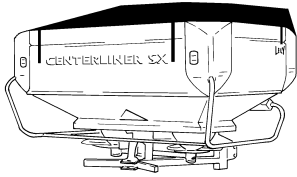

Afdekzeil  
Cover cloth  
Toile de couverture  
Abdeckplane

09

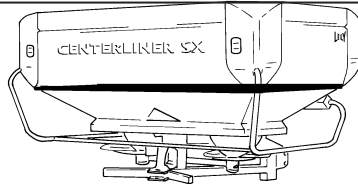

Zeven  
Sieves  
Tamis  
Siebe

10

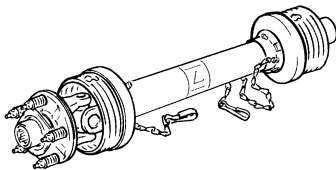

Koppelingsas  
PTO shaf  
Arbre de transmission  
Gelenkwelle

11/12

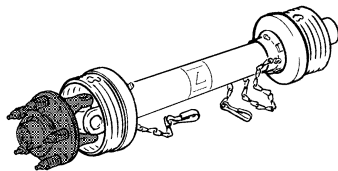

Slipkoppeling  
Friction clutch  
Limiteur à friction  
Reibkupplung

13

Voor Centerliner model met Centronic: zie onderdelenlijst A-SV.018.0400  
For Centerliner model with Centronic: refer to part listt A-SV.018.0400  
Pour modèle Centerliner avec Centronic: voire liste de pièces de rechange A-SV.018.0400  
Für das Centerliner modell mit Centronic: siehe E.T.-Liste A-SV.018.0400



CENTERLINER	type number type number numéro de type Typnummer	vanaf serienummer as from serial number après numéro de série ab Seriennummer
SX	2.3227.0000.1	10501 - 0501
SX	2.3227.0001.1	10510 - 0501

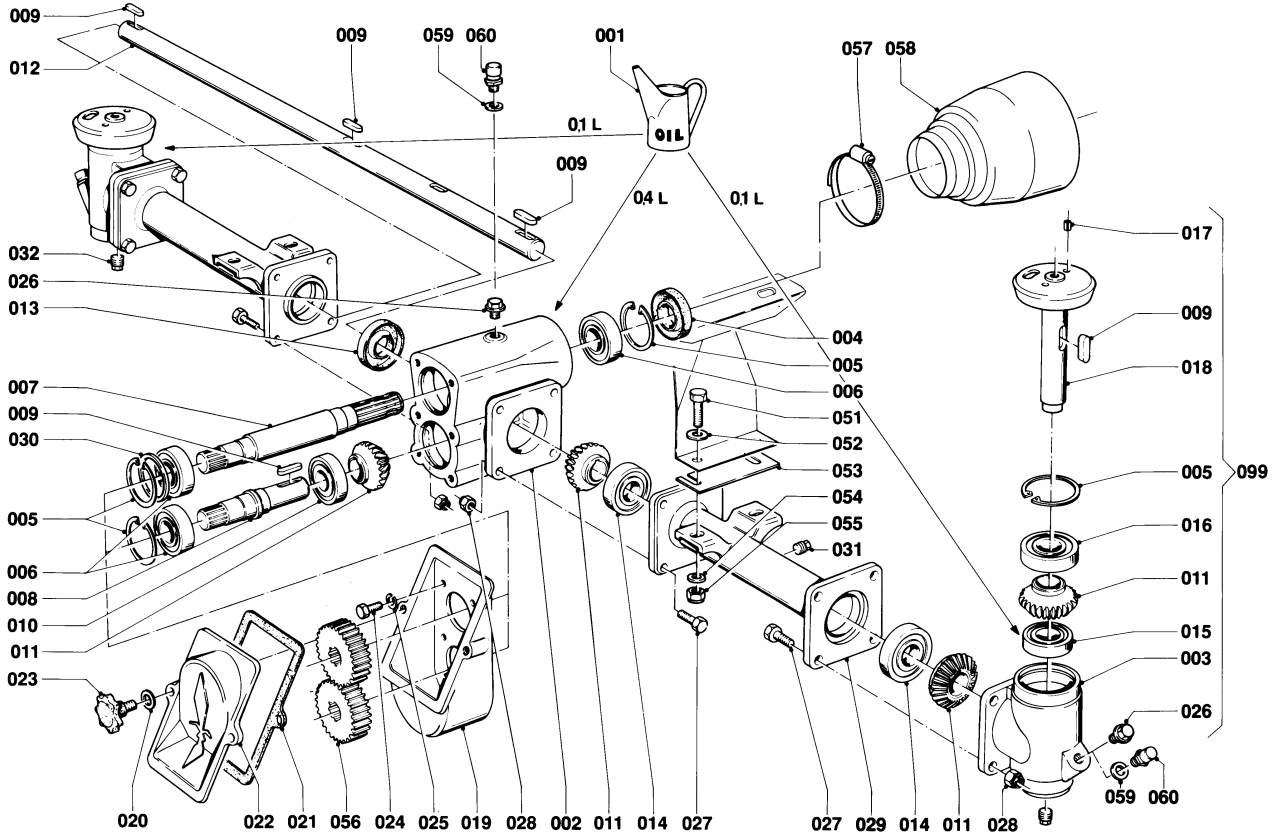
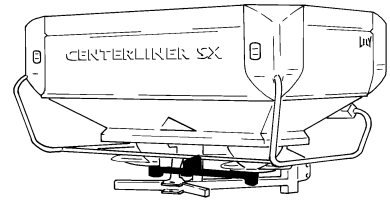

A001.08.00

REF.	ONDERDEELNR. PART NUMBER REFERENCE TEILNUMMER	AANTAL QUANTITY QUANTITE ANZAHL	
001	9.1171.0044.6	(0,6 L)	0,7L GP 80W90 ESSO
002	2.3217.0017.0	1	
003	2.3217.0025.0	2	
004	9.1042.0065.2	1	30x62x10 CB [» «]
005	9.1120.0005.4	5	62x2,00 DIN 472
006	9.1001.0062.5	3	6206 C4
007	2.3217.0021.0	1	1.1/8" (6)
008	2.3217.0022.0	1	
009	9.1071.0009.1	6	A8x7x32 DIN 6885
010	9.1001.0063.6	1	6305 C4
011	2.3217.0024.0	6	
012	2.3225.0669.0	1	
013	9.1042.0054.5	1	25x62x10 CB [» «]
014	9.1001.0061.4	3	6305 2RS1
015	9.1001.0071.0	2	6304 C4
016	9.1001.0075.4	2	6305 2RS1-C3-MT47B
017	9.1070.0050.1	4	Ø8x20 DIN 1481
018	2.3218.0019.0	2	
019	2.3217.0019.0	1	
020	9.1048.0051.3	2	A10,5 DIN 125-A2 [ ]
021	2.3217.0026.0	1	
022	2.3217.0020.0	1	
023	9.1141.0009.1	2	M10x35 DIN 6336
024	9.1113.0013.5	6	M8x16 DIN 933-A2
025	9.1121.0010.1	6	A8 DIN 127 [— —]
026	9.1131.0003.5	3	1/8" Stop(fen)/Plug/Bouchon
027	9.1113.0340.2	16	M8x30 DIN 933-A2
028	9.1030.0020.4	16	M8 DIN 985-A2

REF.	ONDERDEELNR. PART NUMBER REFERENCE TEILNUMMER	AANTAL QUANTITY QUANTITE ANZAHL	
029	2.3225.0668.0	1	[R]
	2.3217.0018.0	1	[L]
030	9.1093.0035.5	~	50x62x0,3 DIN 988 (max. 1x)
031	9.1108.0078.6	1	M12x1
032	9.1131.0015.3	3	1/8" Stop(fen)/Plug/Bouchon
051	9.1113.0319.2	4	M10x35 DIN 933-A2-2
052	9.1048.0051.3	4	A10,5 DIN 125-A2 [— —]
053	2.3217.1482.0	~	d= 1 mm
	2.3217.1488.0	~	d= 2 mm
	2.3217.1483.0	~	d= 4 mm
054	9.1048.0099.2	4	A10 DIN 7349-A2 [— —]
055	9.1030.0022.6	4	M10 DIN 985-A2-2
056	2.3217.0035.1	(1)	16/19 [T+T]
	2.3217.0027.1	-	12/23 [T+T]
	2.3217.0029.1	-	13/22 [T+T]
	2.3217.0031.1	-	14/21 [T+T]
	2.3217.0033.1	-	15/20 [T+T]
	2.3217.0037.1	-	17/18 [T+T]
057	9.1066.0016.6	1	Ø70-Ø90
058	9.1161.0021.0	1	
059	9.1137.0405.2	3	Ø10,5x17x1,5 Cu [— —]
060	9.1150.0014.4	3	1/8" Ontluchter / Breather Reniflard / Entlüfter
099	2.3225.0660.1	1	= REF. 001-032



CENTERLINER	type number type number numéro de type Typnummer	vanaf serienummer as from serial number après numéro de série ab Seriennummer
SX	2.3227.0001.1	10510 - 0501

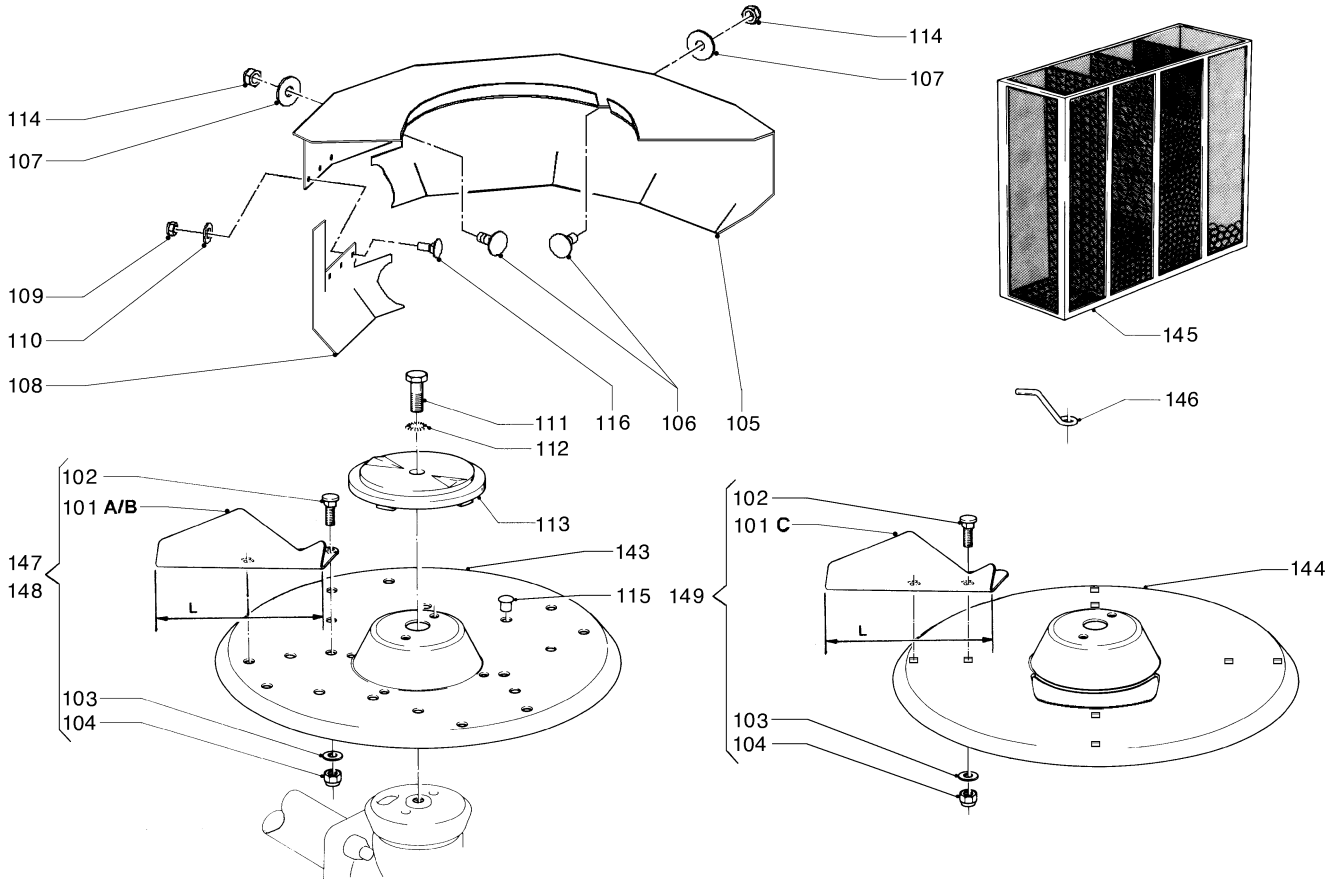
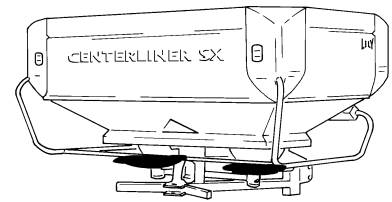

A035.04.31

REF.	ONDERDEELNR. PART NUMBER REFERENCE TEILNUMMER	AANTAL QUANTITY QUANTITE ANZAHL	
------	--	--	--

**Korte schoep / Short spoon / Aube courte / Kurzer Leitschaufel**

101A	2.3224.0148.0	4	[R] L= 217 mm
	2.3224.0149.0	4	[L][x] L= 217 mm
101B	2.3224.0158.0	(4)	[R][x] L= 217 mm
	2.3224.0159.0	(4)	[L][x] L= 217 mm
101C	2.3227.1039.0	(4)	[R][x] L= 217 mm
	2.3227.1035.0	(4)	[L][x] L= 217 mm
102	9.1058.0031.1	16	M8x16 DIN 603-A2-2
103	9.1049.0014.0	16	M8 Nylon [//]
104	9.1030.0020.4	16	M8 DIN 985-A2-2
105	2.3227.0970.0	1	[R]
	2.3227.0960.0	1	[L][x]
106	9.1058.0032.2	6	M8x20 DIN 603-A2-2
107	9.1048.0052.4	6	A8,4 DIN 9021-A2 [—]
108	2.3227.1005.0	1	[R]
	2.3227.1000.0	1	[L][x]

REF.	ONDERDEELNR. PART NUMBER REFERENCE TEILNUMMER	AANTAL QUANTITY QUANTITE ANZAHL	
------	--	--	--

109	9.1030.0021.5	4	M6 DIN 985-A2-2
110	9.1048.0050.2	4	A8,4 DIN 125-A2 [—]
111	9.1113.0377*6	2	M12x40 DIN 933-A2-2
112	9.1051.0009.0	2	A12,5 DIN 6798-A [####]
113	2.3218.1493.0	2	
114	9.1030.0020.4	6	M8 DIN 985-A2-2
115	9.1108.0047.3	16	Ø11,7
116	9.1058.0039.2	4	M6x16 DIN 603-A2-2
143	2.3225.1495.0	2	
144	2.3227.1040.0	(2)	Werpschijf met gat Punched ejector disc Disque éjecteur percé Wurfscheibe mit loch
145	2.3225.0800.0	1	Fraktiometer Grading kit Boîte de granulométrie Bruchteilmessgerät
146	2.3218.2189.0	(2)	Draadagitator (graszaad) Wire agitator (grass seeds) Agitateur à fil (semences de graminées) Drahrührwerk (Grassamen)
147	2.3224.0001.2	1	= REF. 101A+102+103+104
148	2.3224.0001.3	(1)	= REF. 101B+102+103+104
149	2.3227.1030.0	(1)	= REF. 101C+102+103+104



CENTERLINER	type number type number numéro de type Typnummer	vanaf serienummer as from serial number après numéro de série ab Seriennummer
SX	2.3227.0001.1	10510 - 0501

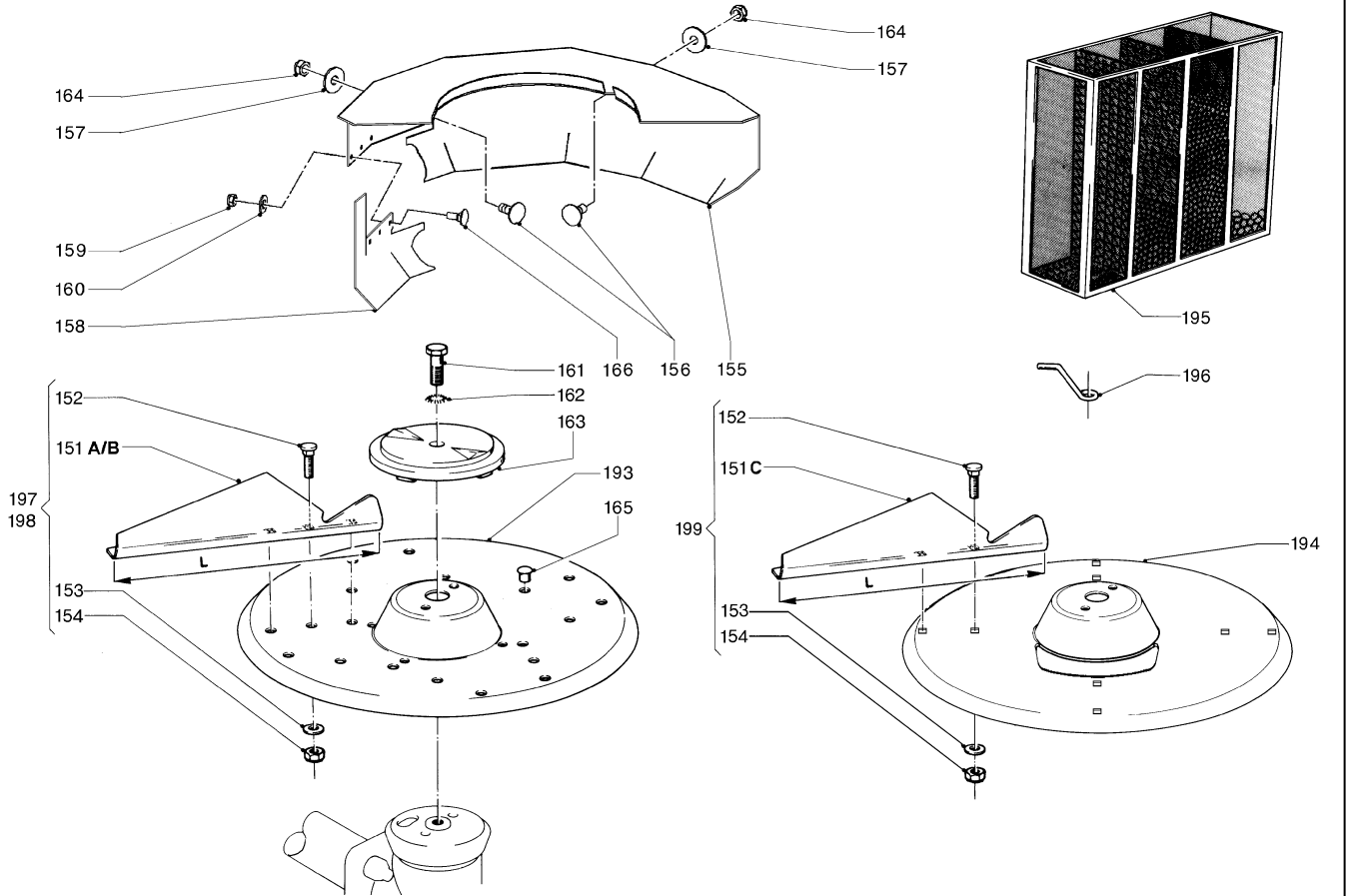
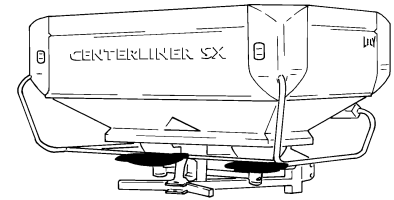

A036.03.31

REF.	ONDERDEELNR. PART NUMBER REFERENCE TEILNUMMER	AANTAL QUANTITY QUANTITE ANZAHL		
------	--	--	--	--

**Lange schoep / Long spoon / Aube lonque / Langer Leitschaufel**

151A	2.3225.1499.0	(4)	A	[R][x]	L= 268 mm
	2.3225.1498.0	(4)	A	[L][x]	L= 268 mm
Roestvrijstalen schoep Stainless steel spoon Aube en acier inoxydable Leitschaufel aus rostfreiem Stahl					
151B	2.3225.1494.0	4	B	[R]	L= 268 mm
	2.3225.1493.0	4	B	[L][x]	L= 268 mm
Schoep van gehard staal Hardened steel spoon Aube en acier durci Leitschaufel aus gehärtetem Stahl					
151C	2.3225.1494.0	(4)	C	[R]	L= 268 mm
	2.3225.1493.0	(4)	C	[L][x]	L= 268 mm
Schoep van gehard staal Hardened steel spoon Aube en acier durci Leitschaufel aus gehärtetem Stahl					
152	9.1058.0031.1	8	A/B	M8x16 DIN 603-A2-2	
	9.1058.0031.1	16	C		
153	9.1049.0014.0	8	A/B	M8 Nylon	[//]
	9.1049.0014.0	16	C		
154	9.1030.0020.4	8	A/B	M8 DIN 985-A2-2	
	9.1030.0020.4	16	C		
155	2.3227.0970.0	1		[R]	
	2.3227.0960.0	1		[L][x]	

REF.	ONDERDEELNR. PART NUMBER REFERENCE TEILNUMMER	AANTAL QUANTITY QUANTITE ANZAHL		
------	--	--	--	--

156	9.1058.0032.2	6		M8x20 DIN 603-A2-2
157	9.1048.0052.4	6		A8,4 DIN 9021-A2 [—]
158	2.3227.0995.0	1		[R]
	2.3227.0990.0	1		[L][x]
159	9.1030.0021.5	4		M6 DIN 985-A2-2
160	9.1048.0050.2	4		A8,4 DIN 125-A2 [—]
161	9.1113.0337.6	2		M12x40 DIN 933-A2-2
162	9.1051.0009.0	2		A12,5 DIN 6798-A2 [####]
163	2.3218.1493.0	2		
164	9.1030.0020.4	6		M8 DIN 985-A2-2
165	9.1108.0047.3	16		Ø11,7
166	9.1058.0039.2	4		M6x16 DIN 603-A2-2
193	2.3225.1495.0	2		Werpschijf met gat
194	2.3227.1040.0	(2)		Punched ejector disc Disque éjecteur percé Wurfscheibe mit loch
195	2.3225.0800.0	1		Fraktiemeter Grading kit Boîte de granulométrie Bruchteilmessgerät
196	2.3218.2189.0	(2)		Draadagitator (graszaad) Wire agitator (grass seeds) Agitateur à fil (semences de graminées) Drahrührwerk (Grassamen)
197	2.3225.0000.2	(1)		= REF. 151A+152+153+154
198	2.3225.0000.3	1		= REF. 151B+152+153+154
199	2.3227.1020.0	(1)		= REF. 151C+152+153+154



CENTERLINER	type number type number numéro de type Typnummer	vanaf serienummer as from serial number après numéro de série ab Seriennummer
SX	2.3227.0000.1	10501 - 0501
SX	2.3227.0001.1	10510 - 0501

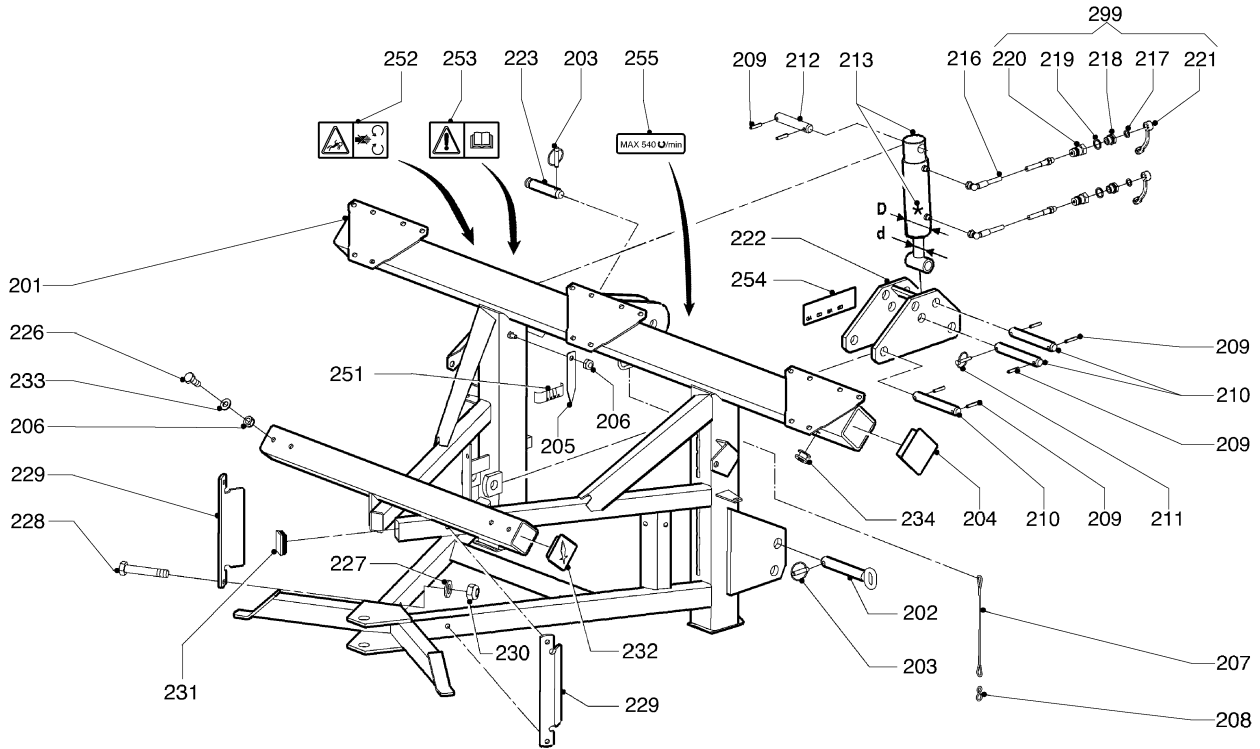
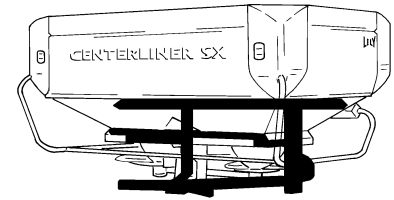

A201.01.10

REF.	ONDERDEELNR. PART NUMBER REFERENCE TEILNUMMER	AANTAL QUANTITY QUANTITE ANZAHL
------	--	--

201	2.3227.0230.0	1
202	2.3227.0310.0	2
203	9.1123.0002*5	3     Ø11
204	9.1108.0104.4	2     100x100
205	2.3217.1487.0	1
206	9.1030.0022.6	5     M10 DIN 985-A2-2
207	2.3222.1486.0	1     Ø4x300
208	9.1147.0006.6	1     Nr. 40-A2
209	9.1070.0061.5	7     Ø8x40 DIN 1481-A2
210	2.3227.1486.0	3     L= 172 mm
211	9.1123.0004*0	1     Ø8
212	2.3227.1485.0	1     L= 132 mm
213	2.3225.0421.0	1     (213 = 213+ ★)
★	2.3225.0429.0	(1)     (d= Ø30, D= Ø60/70) [A+A][x]
216	2.3201.2311.0	2     L= 1810 mm
217	9.1137.0409.6	1+1     Ø13,74x20,57x2,03 [—]
218	9.1137.0603.4	1+1     1/2"-1/4"
219	9.1137.0411.1	1+1     Ø21,54x28,58x2,34 [—]
220	9.1137.0302.4	1+1     1/2" G
221	9.1137.0303.5	1+1     1/2" PVC
222	2.3227.0280.0	1
223	9.1088.0005.1	1     25-95
226	9.1113.0170.1	4     M10x25 DIN 933-A2-2
227	9.1048.0080.4	8     A13 DIN 125-A2 [—]
228	9.1113.0356.4	4     M12x70 DIN 931-A2-2

REF.	ONDERDEELNR. PART NUMBER REFERENCE TEILNUMMER	AANTAL QUANTITY QUANTITE ANZAHL
------	--	--

229	2.3227.1499.0	1     [R]
	2.3227.1497.0	1     [L]
230	9.1030.0023.0	4     M12 DIN 985-A2-2
231	9.1108.0026.2	2     60x40x2,5
232	2.3219.1499.0	2     80x80
233	9.1048.0051.3	4     A10,5 DIN 125-A2 [—]
234	9.1085.0006.5	3
251	9.1170.0162.6	1     0°-15°
252	9.1170.0407.6	1
253	9.1170.0408.0	1
254	9.1170.0277.2	1     "A-B-C-D"
255	9.1170.0125.4	1     "MAX 540/min"
299	2.3201.2312.8	2     = REF. 217-221





CENTERLINER	type number type number numéro de type Typnummer	vanaf serienummer as from serial number après numéro de série ab Seriennummer
SX	2.3227.0001.1	10510 - 0501

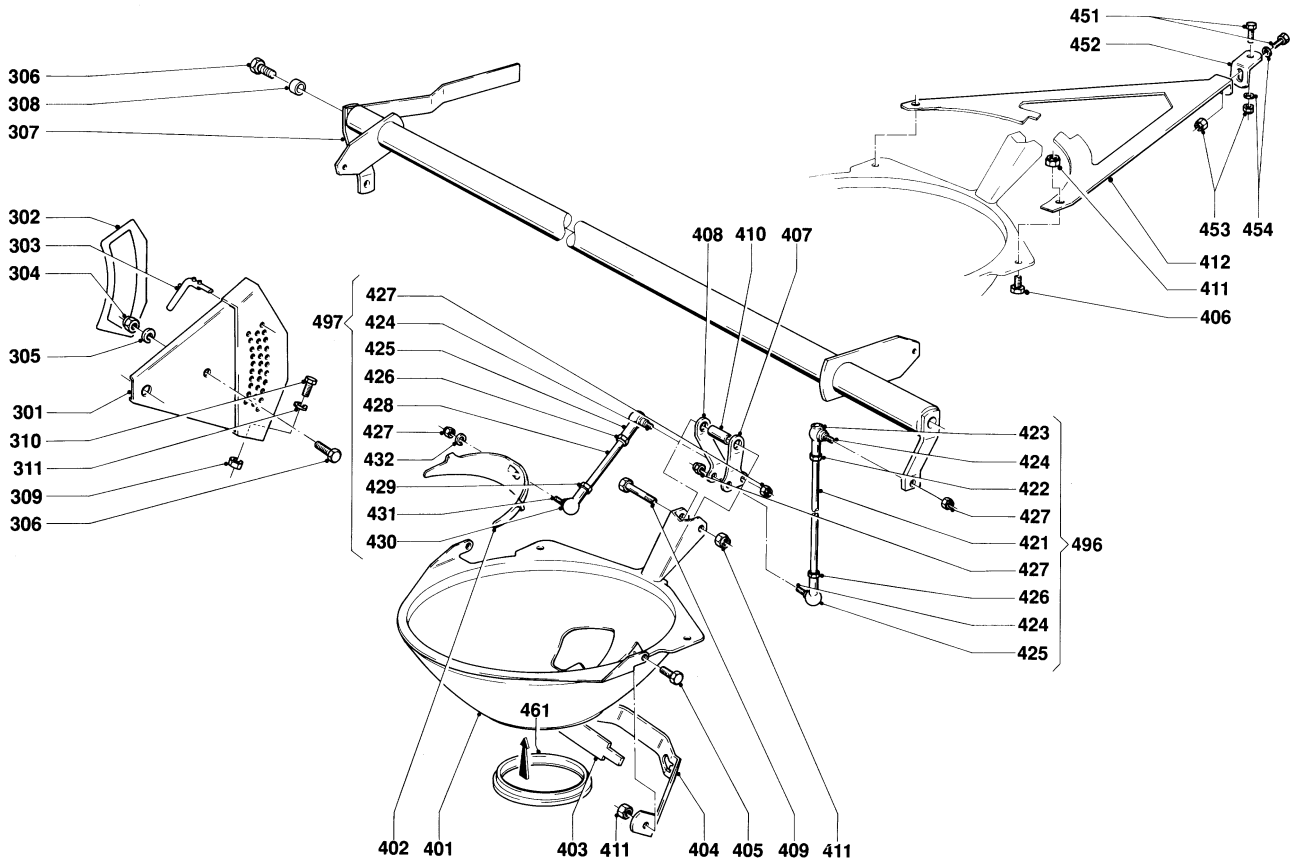
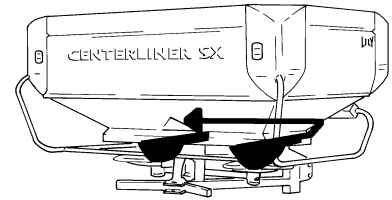

A042.05.30

REF.	ONDERDEELNR. PART NUMBER REFERENCE TEILNUMMER	AANTAL QUANTITY QUANTITE ANZAHL	
------	--	--	--

301	2.3225.0540.0	1	
302	9.1170.0132.4	1	"A-B-C"
303	2.3217.0250.0	1	Cpl.
304	9.1030.0022.6	1	M10 DIN 985-A2-2
305	9.1048.0051.3	2	A10,5 DIN 125-A2 [—]
306	9.1113.0170.1	3	M10x25 DIN 933-A2-2
307	2.3225.0770.0	1	
308	2.3225.1491.0	2	
309	9.1030.0021.5	1	M6 DIN 985-A2-2
310	9.1113.0163.1	1	M6x16 DIN 933-A2-2
311	9.1049.0019.5	1	M6 Nylon [—]
401	2.3218.0110.0	1+1	
402	2.3218.0144.0	1+1	
403	2.3218.0147.0	1+1	
404	2.3218.0145.0	1+1	
405	9.1113.0167.5	2+2	M8x25 DIN 933-A2-2
406	9.1113.0174.5	2+2	M8x20 DIN 933-A2-2
407	2.3218.0148.0	1+1	
408	2.3218.0149.0	1+1	
409	9.1113.0266.6	1+1	M8x65 DIN 931-A2-2
410	2.3218.0146.0	1+1	
411	9.1030.0020.4	5+5	M8 DIN 985-A2-2
412	2.3224.0112.0	1 -	[R]
	2.3224.0132.0	- 1	[L][x]

REF.	ONDERDEELNR. PART NUMBER REFERENCE TEILNUMMER	AANTAL QUANTITY QUANTITE ANZAHL	
------	--	--	--

421	2.3225.0443.0	1+1 -	M8/M8
422	9.1029.0029.0	1+1 -	M8 DIN 934-A2-2
423	9.1038.0013.3	1+1 -	M8-R
424	2.3225.0453.0	2+2/1+1	M6-Ø13
425	9.1038.0014.4	1+1/1+1	M8-L
426	9.1036.0027.5	1+1/1+1	M8-L DIN 934-A2
427	9.1030.0021.5	2+2/2+2	M6 DIN 985-A2-2
428	2.3225.0444.0	- 1+1	M8/M6
429	9.1029.0026.4	- 1+1	M6 DIN 934-A2-2
430	9.1038.0009.6	- 1+1	M6-R
431	2.3225.0454.0	- 1+1	M6-Ø10
432	9.1121.0019.3	- 1+1	A6 DIN 127-A2 [—]
451	9.1113.0167.5	2+2	M8x25 DIN 933-A2-2
452	2.3218.1492.0	1+1	
453	9.1030.0020.4	2+2	M8 DIN 985-A2-2
454	9.1048.0050.2	2+2	A8,4 DIN 125-A2 [—]
461	2.3218.0118.0	(1+1)	
496	2.3225.0443.1	2 -	= REF. 421-427 (2x M8)
497	2.3225.0444.1	- 2	= REF. 424-432 (L= 130 mm)



CENTERLINER	type number type number numéro de type Typnummer	vanaf serienummer as from serial number après numéro de série ab Seriennummer
SX	2.3227.0000.1	10501 - 0501
SX	2.3227.0001.1	10510 - 0501

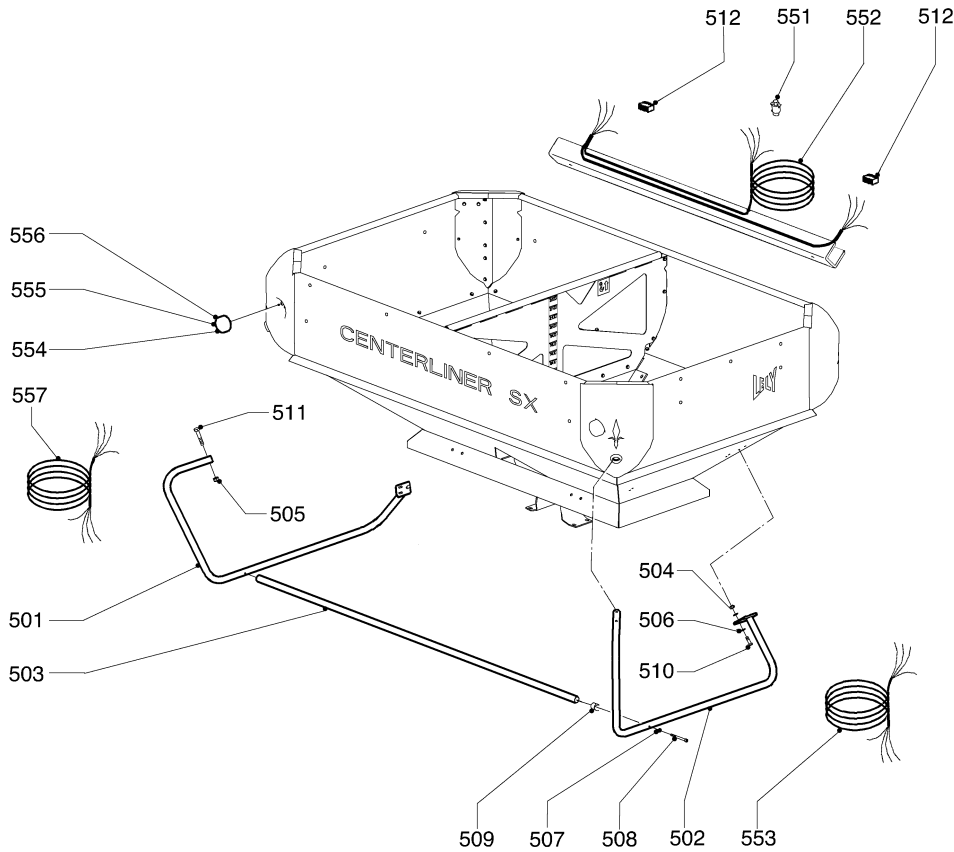
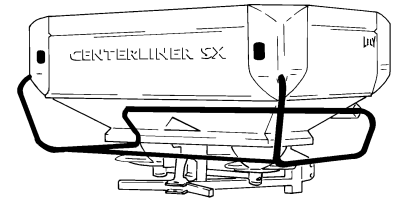

A202.01.01

REF.	ONDERDEELNR. PART NUMBER REFERENCE TEILNUMMER	AANTAL QUANTITY QUANTITE ANZAHL
------	--	--

501	2.3227.0290.0	1	
502	2.3227.0300.0	1	
503	2.3227.1498.0	1	
504	9.1030.0020.4	4	M8 DIN 985-A2-2
505	9.1030.0022.6	4	M10 DIN 985-A2-2
506	9.1048.0050.2	8	A8,4 DIN 985 A2
507	9.1049.0019.5	2	M6 Nylon
508	9.1057.0091.5	2	M6x70 DIN 912-A2
509	9.1108.0103.3	2	
510	9.1113.0167.5	4	M8x25 DIN 933-A2-2
511	9.1113.0322.5	4	M10x55 DIN 931-A2-2
512	9.1186.0170.5	2	

REF.	ONDERDEELNR. PART NUMBER REFERENCE TEILNUMMER	AANTAL QUANTITY QUANTITE ANZAHL
------	--	--

551	9.1186.0184.5	1	7-polige stekker 7-pole plug fiche 7 pôles 7-poliger Stecker
552	9.1186.0183.4 (6.2001.0048.0)	1	verlichtingskabel machine lightning cable machine câble d'éclairage machine Beleuchtungskabel Maschine
553	9.1186.0182.3	1	verlichtingskabel beugel rechts lightning cable bracket right câble d'éclairage arceau droit Beleuchtungskabel Halterung rechts
554	9.1096.0008.3	2	lamphouder HELLA lamp holder HELLA porte-lampe HELLA Leuchenträger HELLA
555	9.1096.0009.4	2	buislamp 12V 18W strip light 12V 18W lampe à tube 12V 18W Leuchtröhre 12V 18W
556	9.1096.0010.5	2	ballonlamp 12V P21/5W bulb 12V P21/5W lampe à ampoule 12V P21/5W Kolben 12V P21/5W
557	9.1186.0181.2	1	verlichtingskabel beugel links lightning cable bracket left câble d'éclairage arceau gauche Beleuchtungskabel Halterung links



CENTERLINER	type number type number numéro de type Typnummer	vanaf serienummer as from serial number après numéro de série ab Seriennummer
SX	2.3227.0000.1	10501 - 0501
SX	2.3227.0001.1	10501 - 0501

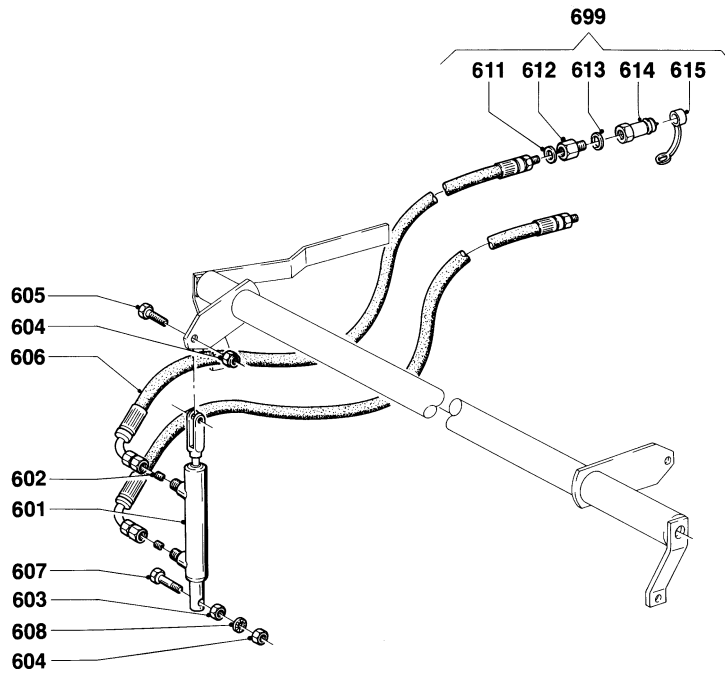
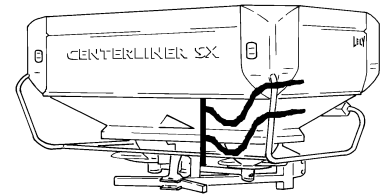

A037.03.11

REF.	ONDERDEELNR. PART NUMBER REFERENCE TEILNUMMER	AANTAL QUANTITY QUANTITE ANZAHL	
------	--	--	--

601	2.3218.2170.0	1	(601= 601+602)
602	2.3201.2400.0	2	M8x8 DIN 916-45H (Ø1,6)
603	9.1029.0029.0	1	M8 DIN 934-A2-2
604	9.1030.0020.4	2	M8 DIN 985-A2-2
605	9.1113.0340.2	1	M8x30 DIN 933-A2-2
606	2.3201.2311.0	2	L= 1810 mm
607	9.1113.0363.4	1	M8x50 DIN 933-A2-2
608	9.1051.0007.5	1	A8,2 DIN 6798-A2 [#####]
611	9.1137.0409.6	1+1	Ø13,74x20,57x2,03 [——]
612	9.1137.0603.4	1+1	1/2"-1/4"
613	9.1137.0411.1	1+1	Ø21,54x28,58x2,34 [——]
614	9.1137.0302.4	1+1	1/2" G
615	9.1137.0303.5	1+1	1/2" PVC
699	2.3201.2312.8	2	= REF. 611-615

REF.	ONDERDEELNR. PART NUMBER REFERENCE TEILNUMMER	AANTAL QUANTITY QUANTITE ANZAHL	
------	--	--	--



CENTERLINER	type number type number numéro de type Typnummer	vanaf serienummer as from serial number après numéro de série ab Seriennummer
SX	2.3227.0000.1	10501 - 0501
SX	2.3227.0001.1	105010 - 0501

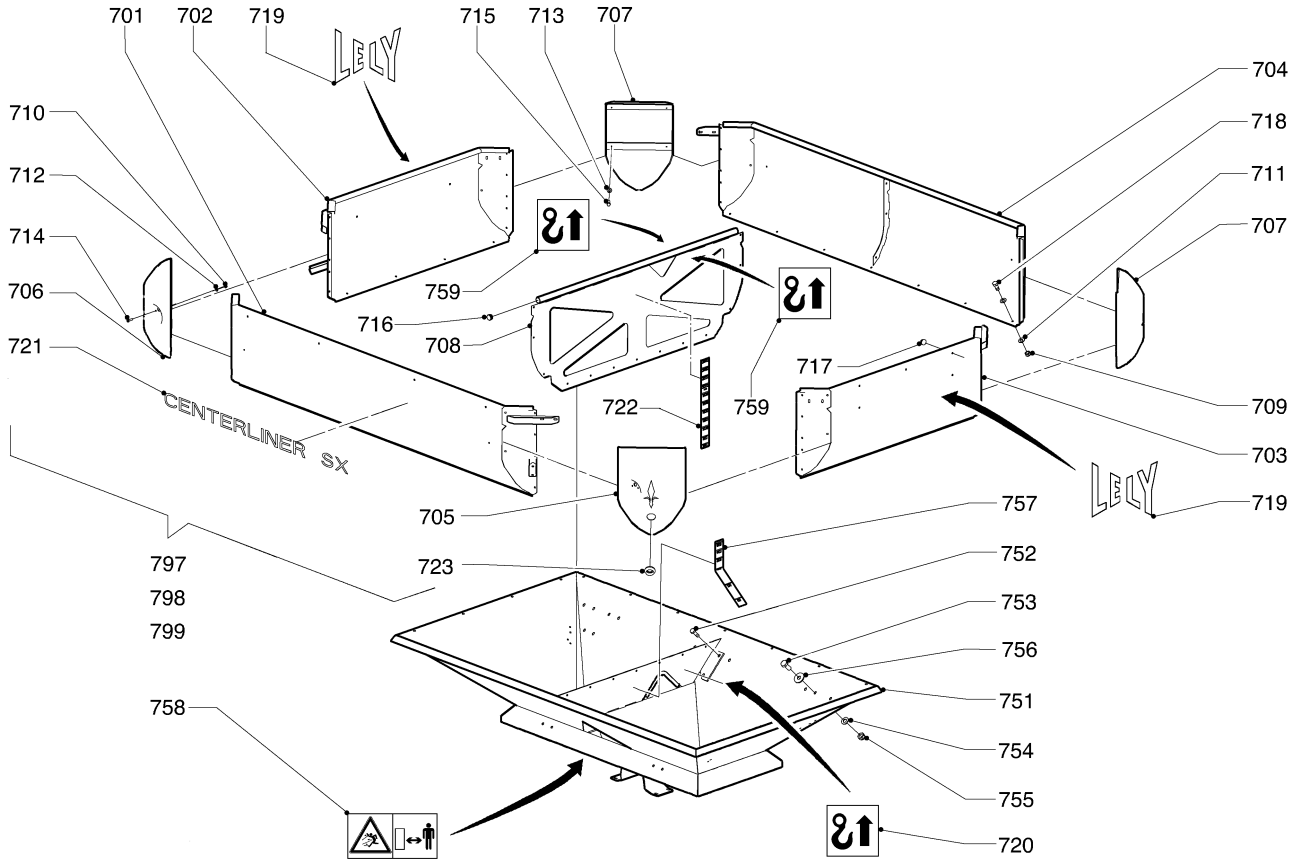
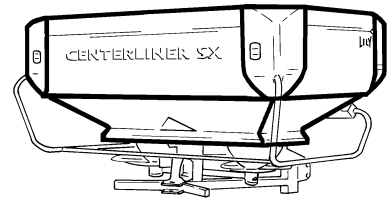

A203.01.01

REF.	ONDERDEELNR. PART NUMBER REFERENCE TEILNUMMER	AANTAL QUANTITY QUANTITE ANZAHL
------	--	--

797 798 799

701	2.3227.0410.0 2.3227.0510.0 2.3227.0610.0	1 - - [x] - 1 - - - 1 [x]
702	2.3227.0420.0 2.3227.0520.0 2.3227.0620.0	1 - - [x] - 1 - - - 1 [x]
703	2.3227.0430.0 2.3227.0530.0 2.3227.0630.0	1 - - [x] - 1 - - - 1 [x]
704	2.3227.0440.0 2.3227.0540.0 2.3227.0640.0	1 - - [x] - 1 - - - 1 [x]
705	2.3227.0457.0 2.3227.0557.0 2.3227.0657.0	1 - - [x] - 1 - - - 1 [x]
706	2.3227.0458.0 2.3227.0558.0 2.3227.0658.0	1 - - [x] - 1 - - - 1 [x]
707	2.3227.0459.0 2.3227.0559.0 2.3227.0659.0	2 - - [x] - 2 - - - 2 [x]
708	2.3227.0460.0 2.3227.0560.0 2.3227.0660.0	1 - - [x] - 1 - - - 1 [x]

REF.	ONDERDEELNR. PART NUMBER REFERENCE TEILNUMMER	AANTAL QUANTITY QUANTITE ANZAHL
------	--	--

709	9.1030.0020.4	63 M8 DIN 985-A2-2
710	9.1030.0033.3	4 M4 DIN 985-A2-2
711	9.1048.0050.2	126 A8,4 DIN 125-A2 [—]
712	9.1048.0089.6	4 A4,3 DIN 125-A2 [—]
713	9.1048.0090.0	16 A6,4 DIN 125-A2 [—]
714	9.1059.0009.6	4 M4x16 DIN 7985-A2
715	9.1064.0117.4	16 5,5x25 DIN 7976-A2
716	9.1108.0085.6	2 Ø32
717	9.1108.0106.6	22 Ø9
718	9.1113.0174.5	63 M8x20 DIN 933-A2-2
719	9.1170.0001.6	2 "LELY"
720	9.1170.0173.3	2
721	9.1170.0473.2	1 "CENTELINER SX"
722	9.1170.0475.4	2 "2200 L"/"2600 L"/"3000 L"
723	9.1180.0056.2	2
751	2.3227.0200.0	1
752	9.1113.0319.2	4 M10x35 DIN 933-A2-2
753	9.1113.0170.1	14 M10x25 DIN 933-A2-2
754	9.1048.0051.3	18 A10,5 DIN 125-A2 [—]
755	9.1030.0022.6	18 M10 DIN 985-A2-2
756	9.1048.0104.0	18 A10 DIN 9021-A2 [—]
757	9.1170.0474.3	2
758	9.1170.0410.2	1
759	9.1170.0173.3	2
797	2.3227.0400.0	1 = REF. 701-723[x] "SX 4000"
798	2.3227.0500.0	1 = REF. 701-723 "SX 5000"
799	2.3227.0600.0	1 = REF. 701-723[x] "SX 6000"



CENTERLINER	type number type number numéro de type Typnummer	vanaf serienummer as from serial number après numéro de série ab Seriennummer
SX	2.3227.0000.1	10501 - 0501
SX	2.3227.0001.1	10510 - 0501

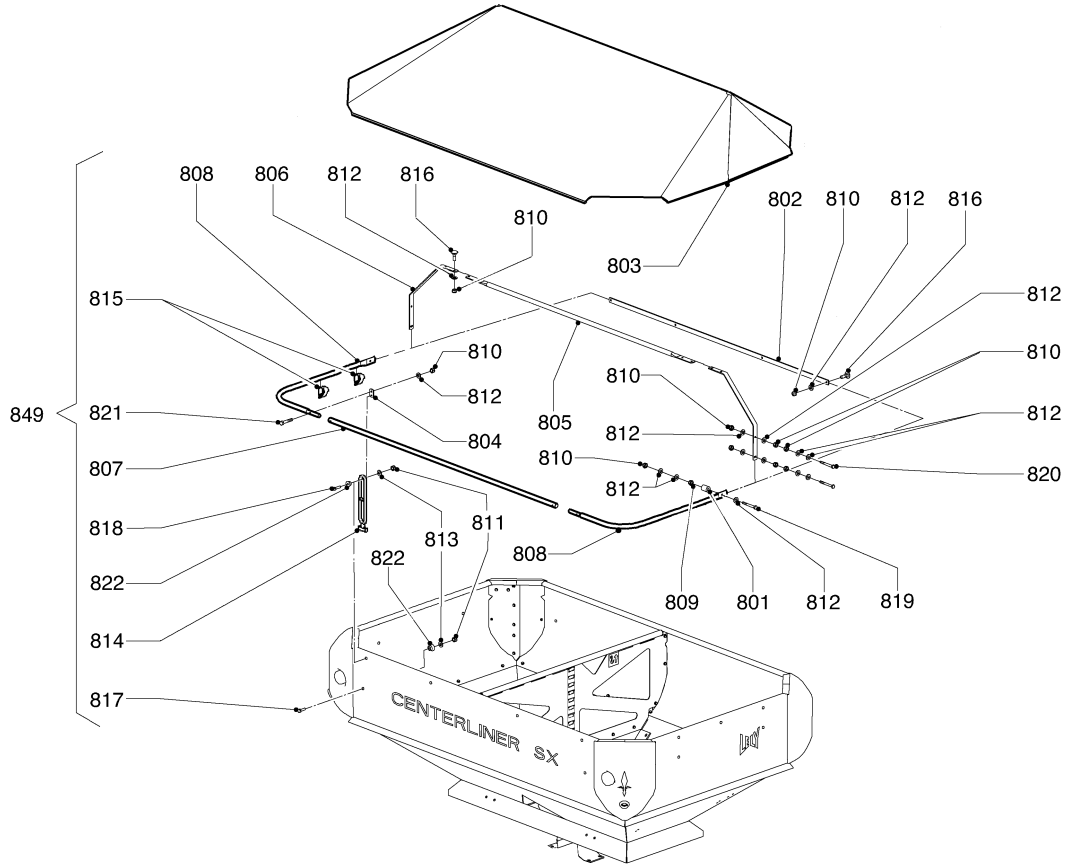
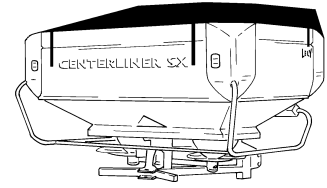

A204.01.01

REF.	ONDERDEELNR. PART NUMBER REFERENCE TEILNUMMER	AANTAL QUANTITY QUANTITE ANZAHL
------	--	--

801	2.3227.0871.0	2
802	2.3227.0873.0	1
803	2.3227.0874.0	1
804	2.3227.0875.0	2
805	2.3227.0877.0	1
806	2.3227.0878.0	2
807	2.3227.0879.0	1
808	2.3227.0880.0	2
809	9.1029.0029.0	2 M8 DIN 934-A2-2
810	9.1030.0020.4	24 M8 DIN 985-A2-2
811	9.1030.0021.5	4 M6 DIN 985-A2-2
812	9.1048.0050.2	32 A8,4 DIN 125-A2 [ ]
813	9.1048.0090.0	4 A6,4 DIN 125-A2 [ ]
814	9.1054.0008.3	2
815	9.1054.0009.4	4
816	9.1058.0053.2	8 M8x25 DIN 603-A2-2
817	9.1113.0164.2	2 M6x20 DIN 933-A2-2
818	9.1113.0308.6	2 M6x25 DIN 933-A2-2
819	9.1113.0363.4	2 M8x50 DIN 933-A2-2
820	9.1113.0164.5	4 M8x70 DIN 933-A2-2
821	9.1113.0165.6	2 M8x45 DIN 931-A2-2
822	9.1141.0015.0	4 Nr. 71

REF.	ONDERDEELNR. PART NUMBER REFERENCE TEILNUMMER	AANTAL QUANTITY QUANTITE ANZAHL
------	--	--

849 2.3227.0720.0 1 = REF. 801-822



CENTERLINER	type number type number numéro de type Typnummer	vanaf serienummer as from serial number après numéro de série ab Seriennummer
SX	2.3227.0000.1	10501 - 0501
SX	2.3227.0001.1	10510 - 0501

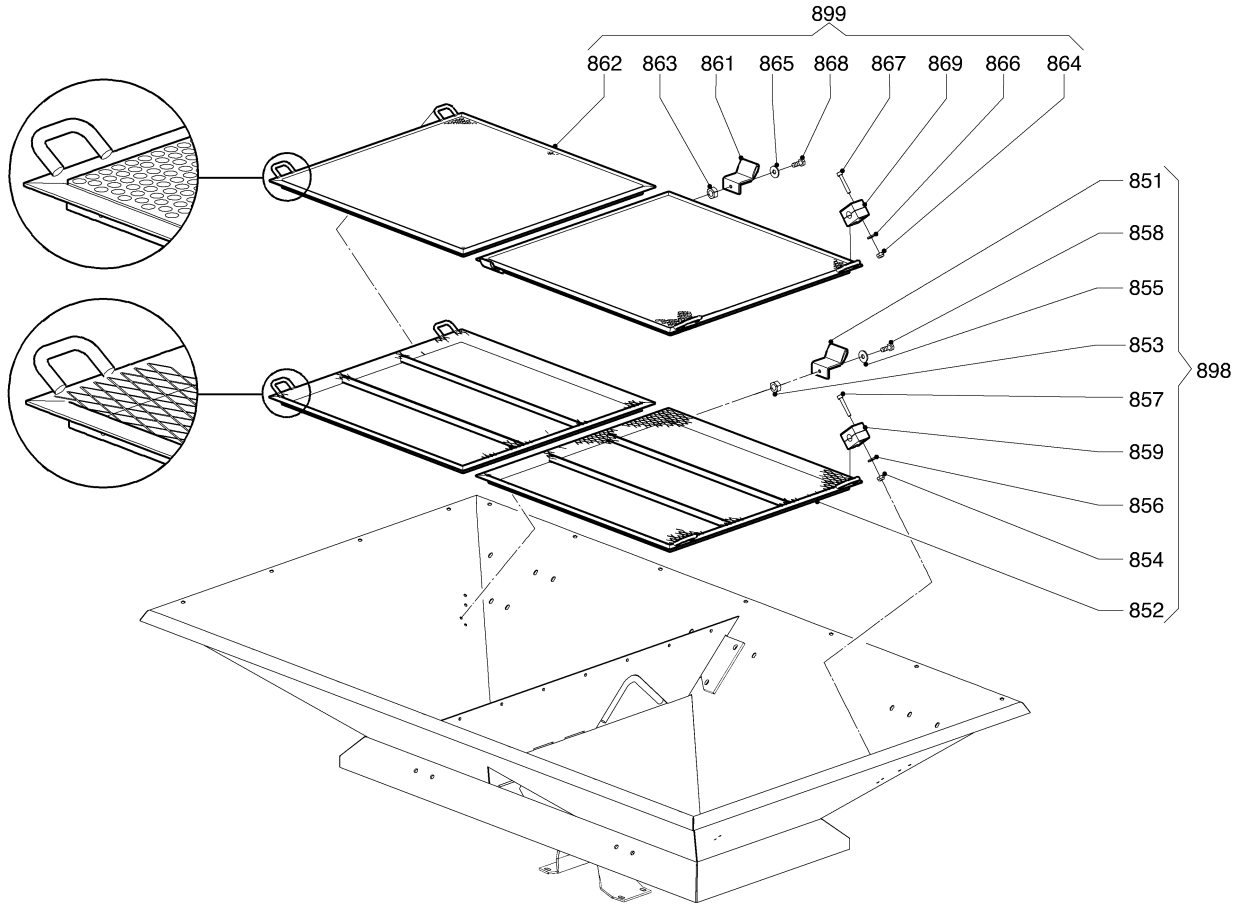
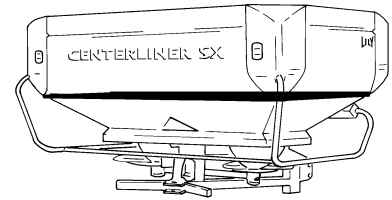

A205.01.01

REF.	ONDERDEELNR. PART NUMBER REFERENCE TEILNUMMER	AANTAL QUANTITY QUANTITE ANZAHL	
------	--	--	--

851	2.3218.0269.0	4	
852	2.3227.0710.0	2	
853	9.1029.0027.5	4	M6 DIN 934-Nylon 6.6
854	9.1030.0021.5	8	M6 DIN 985-A2-2
855	9.1048.0049.1	4	A6,4 DIN 9021Nyl.6.6 [—]
856	9.1048.0090.0	8	A6,4 DIN 125-A2 [—]
857	9.1057.0076.5	8	M6x40 DIN 912-A2-2
858	9.1113.0166.4	4	M6x16 DIN 933-Nylon 6.6
859	9.1137.0946.4	4	

898 2.3227.0700.0 2 = REF. 851-859

REF.	ONDERDEELNR. PART NUMBER REFERENCE TEILNUMMER	AANTAL QUANTITY QUANTITE ANZAHL	
------	--	--	--

861	2.3218.0269.0	4	
862	2.3227.0760.0	2	
863	9.1029.0027.5	4	M6 DIN 934-Nylon 6.6
864	9.1030.0021.5	8	M6 DIN 985-A2-2
865	9.1048.0049.1	4	A6,4 DIN 9021Nyl.6.6 [—]
866	9.1048.0090.0	8	A6,4 DIN 125-A2 [—]
867	9.1057.0076.5	8	M6x40 DIN 912-A2-2
868	9.1113.0166.4	4	M6x16 DIN 933-Nylon 6.6
869	9.1137.0946.4	4	

899 2.3227.0750.0 2 = REF. 861-869



CENTERLINER	type number type number numéro de type Typnummer	vanaf serienummer as from serial number après numéro de série ab Seriennummer
SX	2.3227.0000.1	10501 - 0501
SX	2.3227.0001.1	10510 - 0501

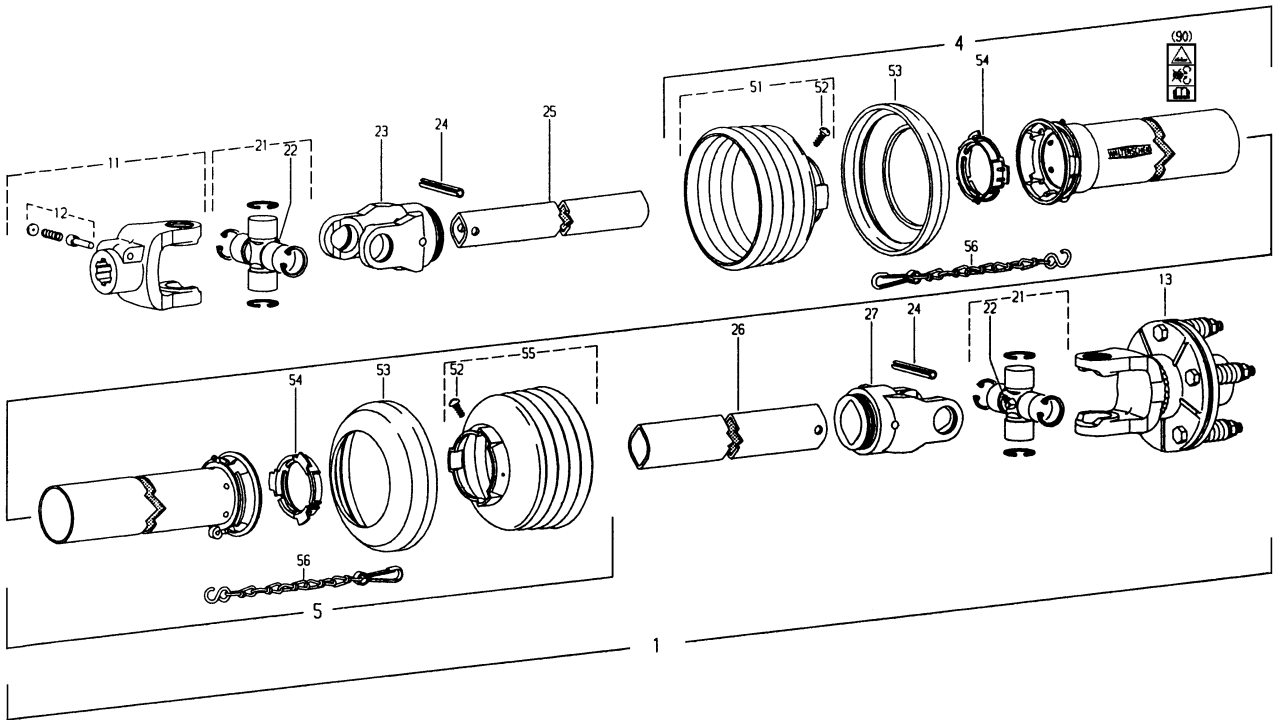
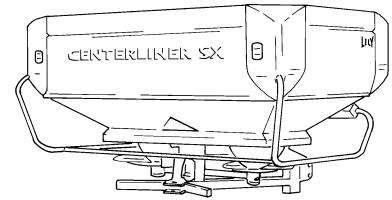

Aw001.07.11

REF.	ONDERDEELNR. PART NUMBER REFERENCE TEILNUMMER	AANTAL QUANTITY QUANTITE ANZAHL	
------	--	--	--

1	9.1154.0177.2	1	W2102-SD05SW-860-K94/1 = REF. 11-90
4	85.035	1	SDH05SW-A705-RP10-K
5	85.034	1	SDH05SW-J700-RP10-K
11	10.10.00	1	1.3/8" (6)
12	33.91.07	1	AGRASET 101
13	56.111.19	1	K94/1-2100-1.1/8"(6)AS; M= 400 Nm
21	10.01.00	2	Cpl.
22	63.27.00	2	BM 8x1
23	10.48.00	1	RG2100-00a
24	9.1070.0023.2	2	Ø8x50 DIN1481
25	75.06.15	1	00a-760
26	75.12.15	1	0a-755
27	10.49.00	1	RG 2100-0a
51	85.05.35	1	n= 5
52	60.15.00	2	4x10
53	83.10.03	2	
54	83.09.01	2	
55	85.05.36	1	n= 6
56	82.36.03	2	
90	11.87.45	1	

REF.	ONDERDEELNR. PART NUMBER REFERENCE TEILNUMMER	AANTAL QUANTITY QUANTITE ANZAHL	
------	--	--	--



CENTERLINER	type number type number numéro de type Typnummer	vanaf serienummer as from serial number après numéro de série ab Seriennummer
SX	2.3227.0000.1	10501 - 0501
SX	2.3227.0001.1	10510 - 0501

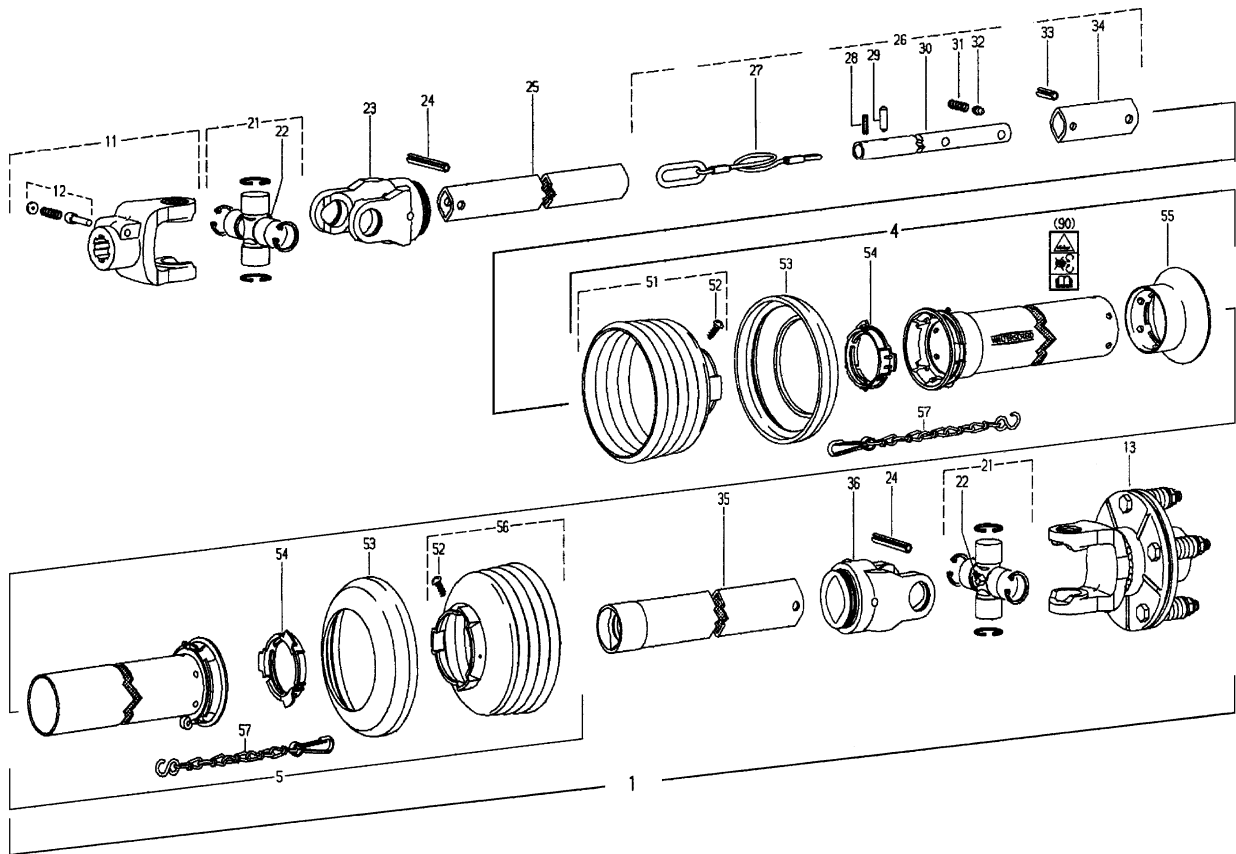
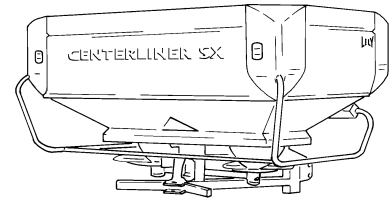

Aw008.01.10

REF.	ONDERDEELNR. PART NUMBER REFERENCE TEILNUMMER	AANTAL QUANTITY QUANTITE ANZAHL	
1	9.1154.0205.2	1	WTS2102-SD05SW-860-K94/1 = REF. 11-90
4	85.017	1	SDH05SW-A690-RP5-K-WTS
5	85.034	1	SDH05SW-J710-RP10-K
11	10.10.00	1	1.3/8" (6)
12	33.91.07	1	AGRASET 101
13	56.111.19	1	K94/1-2100-1.1/8" (6)AS; M= 400 Nm
21	10.01.00	2	Cpl.
22	63.27.00	2	BM 8x1
23	10.48.00	1	RG2100-00a
24	9.1070.0023.2	2	Ø8x50 DIN1481
25	75.02.15	1	00c-690
26	69.12.02	1	WTS-605
27	16.50.560	1	3x605
28	30.42.61	1	DIN 1481-4x16
29	16.50.562	1	6x21,2
30	69.12.01	1	WTS-16x380
31	66.01.54	1	
32	16.50.563	1	
33	61.04.16	1	DIN 7346-8x22
34	75.02.101	1	00c-80-WTS
35	75.12.134	1	0a-WTS-755
36	10.49.00	1	RG2100-0a

REF.	ONDERDEELNR. PART NUMBER REFERENCE TEILNUMMER	AANTAL QUANTITY QUANTITE ANZAHL	
51	85.05.35	1	n= 5
52	60.15.00	2	4x10
53	83.10.03	2	
54	83.09.01	2	
55	85.02.00	1	SC05SW-GWK
56	82.05.36	1	n= 6
57	82.36.03	2	
90	11.87.45	1	





CENTERLINER	type number type number numéro de type Typnummer	vanaf serienummer as from serial number après numéro de série ab Seriennummer
SX	2.3227.0000.1	10501 - 0501
SX	2.3227.0001.1	10510 - 0501

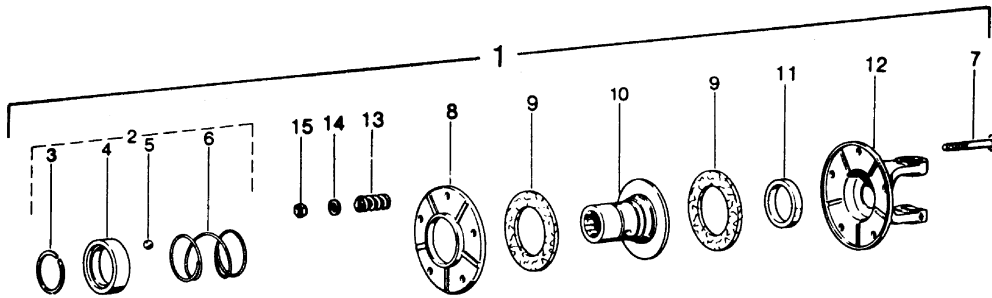
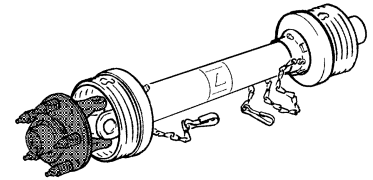

Aw002.03.00

REF.	ONDERDEELNR. PART NUMBER REFERENCE TEILNUMMER	AANTAL QUANTITY QUANTITE ANZAHL	
------	--	--	--

1	56.111.19	(1)	K94/1-2100 1.1/8" (6); 400 Nm = REF. 3-15
2	19.36.58	1	AGRASET 140 = REF. 3-6
3	62.07.04	1	SW43
4	16.50.493	1	43x58
5	64.01.00	3	3/8"-5 DIN 5401
6	66.01.55	1	
7	9.1113.0175*6	5	M8x60 DIN 931
8	16.20.69	1	
9	56.73.13	2	56x90
10	16.50.494	1	1.1/8" (6)
11	16.52.05	1	43x53
12	10.34.121	1	K94/1-2100
13	66.01.47	5	
14	9.1048.0004*5	5	B8,4 DIN 125
15	9.1030.0012*3	5	M8 DIN 985

REF.	ONDERDEELNR. PART NUMBER REFERENCE TEILNUMMER	AANTAL QUANTITY QUANTITE ANZAHL	
------	--	--	--

[ — ]