



PEECON

Biga Series



USER MANUAL 2026

Biga Longlife | Biga Topliner Future | Big Topliner Mammoet Future | Biga Eco Future
Biga Twin Future | Biga Twin plus Future | Biga Lowliner Future | Biga Twin wide Body Future |
Biga Mammoet Future | Biga Mega Mammoet Future | Biga Twin Scoop Future | Biga Scoop
Future | Biga Twin Pacman Future

The main function of this document is to ensure safe and efficient interaction between man and machine. Keep this document for future use.

© Copyright 2025

All rights reserved. No part of this publication may be reproduced, or placed in an automated database, or made public, in any form or by any means, electronic, mechanical, by photocopying, recording, or in any way, without the prior written permission of Peeters Group B.V. This also applies to the accompanying drawings and diagrams.

Peeters Group B.V. reserves the right to change parts at any time, without prior or direct notice to the customer.

The content of this user manual is also subject to change without prior warning. For information regarding setup, maintenance operations or repairs not covered by this user manual, please contact the technical service department of your supplier.

This user manual has been prepared with all possible care, but Peeters Group B.V. cannot accept any responsibility for any errors in this user manual or for the consequences thereof.

Table of contents

Table of contents	3
1. Introduction	5
1.1. Foreword	5
1.2. Warranty and liability	6
1.3. EG Declaration of Conformity	7
1.4. Safety instructions	8
1.5. Type designation	8
2. Technical specifications	9
3. Application of the machine	12
4. Important safety precautions	13
4.1. Algemeen	13
4.2. Danger zone	15
4.3. Attaching and detaching the machine	16
4.4. Operating the machine	16
4.5. Safety symbols	16
4.5.1. Explanation of safety symbols	17
4.5.2. Safety symbols on the machine	21
4.6. Brake system	23
4.7. Extreme conditions	23
5. Machine operation	24
6. Initial commissioning	26
6.1. Chassis	26
6.2. Drawbar	27
6.3. Drawbar eyes	27
6.4. PTO shaft	28
6.5. Lighting	28
6.6. Hydraulic hoses	29
7. Attaching and detaching	30
7.1. Attaching	30
7.2. Detaching	31
8. Operating the machine	32
8.1. Operation	33
8.2. Loading	33
8.3. Loading sequence	33
8.4. Mixing	34
8.5. Discharging	34
9. Maintenance of the machine and personal protective equipment (PPE)	35
9.1. Maintenance intervals	35
9.2. Fluid specifications	36
9.3. Auger drive line	36
9.3.1. Planetary reduction gearboxes	36
9.3.2. Manual transmission (option)	38
9.3.3. Drive shafts	38
9.4. Augers	39
9.4.1. Auger type 1	39
9.4.2. Auger type 2	40
9.4.3. Replacing auger knives	41
9.5. Magnets	41
9.6. Discharge door	41
9.7. Discharge conveyor (option)	42
9.7.1. Types of discharge conveyors	42
9.7.2. Cleaning the conveyor	42
9.7.3. Tensioning the conveyor belt	42
9.7.4. Discharge chain	43
9.8. Axles	43
9.8.1. Hydraulically braked axles	44
9.8.2. Pneumatically braked axles	44
9.8.3. Tandem axles	44
9.8.4. Tridem axles	45
9.8.5. Wheel bearings	45
9.9. Hydraulic hoses	45
9.10. Wheel nuts, chassis bolts and drawbar eyes	46
10. Malfunctions	47
11. System diagrams	49
11.1. Electrical diagram	49
11.2. Hydraulic diagram	50
11.3. Weighing system diagram – Biga	50
11.4. Weighing system diagram - Biga Topliner	51
12. Safety Data Sheets liquids	52
1.6. Planetary gearboxes	52
1.7. General purpose grease	52

1. Introduction

1.1. Foreword

Congratulations on the purchase of your new Peecon Biga vertical feed mixer. With this machine, you are assured of quality and reliability.

The Peecon Biga series has been developed based on an extensive research and testing program. One of the primary objectives was to design machines that, in terms of use, operation, safety, maintenance, and service life, fully comply with European directives and international standards applicable to feed mixers.

Before operating the machine, please read this manual carefully and ensure that you understand all the information provided. Doing so will contribute to safe operation, optimal performance, and a long service life of the machine. Always keep this manual with the machine so it can be easily referenced.

You can request the most recent version of this manual from your dealer. A digital version is also available at: <https://peecon.com/downloads>

If you have any questions or encounter any issues not addressed in this manual, please contact your dealer or Peeters Landbouwmachines B.V.

No warranty can be provided for damage resulting from improper operation or incorrect use. If you are unsure about any operation, maintenance, or repair procedure, always consult a qualified professional.

The manufacturer reserves the right to make changes to the machine without prior notice. The illustrations, dimensions, and weights included in this manual may be subject to change and are therefore non-binding.

Authorized personnel are individuals who:

- Have acquired a certain level of knowledge through education/training (internal courses specific to the Biga feed mixer) and who possess the necessary skills to operate the machine.

Technically qualified personnel are individuals who:

- Are authorized and have acquired a certain technical knowledge level (at least equivalent to a vocational education diploma) through education/training, who are familiar with the machine's technology, and who are aware of potential hazards and risks.
- Are authorized to set up, operate, clean, and perform maintenance on the machine (for example, a service technician from Peeters Landbouwmachines B.V.).

1.2. Warranty and liability

To avoid any misunderstandings, we kindly ask you to read this manual in its entirety. We have taken great care to ensure the safety and functionality of your machine. Below you will find the key information regarding warranty and liability.

Each machine is carefully inspected at the factory to rule out material and manufacturing defects. Should any defects nevertheless occur, Peeters Landbouwmachines B.V. will supply defective parts free of charge for a period of 12 months or 750 operating hours after delivery (whichever comes first), with the exception of wear parts.

The warranty will be void in the following cases:

- If you deviate from the operating and maintenance instructions outlined in this manual without written approval from the manufacturer.
- If maintenance is not performed in accordance with the prescribed maintenance schedule. These maintenance activities must be documented.
- If non-original parts are used during maintenance or repairs. Original parts are listed in the parts catalog, which can be downloaded at: <https://peecon.com/downloads>
- If the user declaration below is not fully completed, signed, scanned, and submitted by the purchaser.
- If any modifications are made to the machine without prior approval from Peeters Landbouwmachines B.V.
- If the machine is resold.

The warranty is limited to the supply of replacement parts and does not cover:

- Loss of income due to machine downtime.
- Transportation costs to and from a workshop.
- Costs of special tools.
- Labor costs for technicians.

To submit a warranty claim, please contact your dealer. The cost of parts may initially be charged and will be reimbursed after inspection by an authorized dealer or Peeters Landbouwmachines B.V.

User declaration

Please record the following information about your machine. This will help when reporting issues or ordering parts.

1. Model: Biga _____ 2. Delivery date: _____

3. Machine serial number: _____

By signing below, the user confirms that the manual has been read and fully understood:

Name: _____

Signature: _____

1.3. EG Declaration of Conformity



PEETERS GROUP
The Dutch innovators
Munnikenheiweg 47 | 4879 NE Etten-Leur | NL



Technical documentation available on site aforementioned manufacturer.

EG DECLARATION OF CONFORMITY



The undersigned hereby certifies that the machine:

Brand: Biga
Models: Peecon Biga (VMW/VME/VML/VMS/VMP/VMT)
Building year:
Series nr: 510
Category: Feed mixer (Intended for mixing and spreading silage/livestock feed)

Complies with the following European directives:

- (EU) 2023/1230 Machinery directive
- NEN-EN 703: 2021 en Processing of silage

Location: Etten-Leur
Date:

D.P.M. Peeters
Managing director



1.4. Safety instructions

Incorrect or careless operation can lead to accidents. For this reason, read all instructions carefully and comply with the safety regulations at all times. Also refer to the manuals of other components, such as the tractor or the PTO shaft. Anyone operating the machine must be familiar with these instructions.



CAUTION! The terms “left,” “right,” “front’ and “rear” are always considered from the tractor's direction of travel.

This manual uses various symbols:

Symbol	Meaning
	WARNING OF DANGER OR DAMAGE Warnings and additional information.
	TIPS AND RECOMMENDATIONS Suggestions and advice to help you perform your tasks more easily.

1.5. Type designation

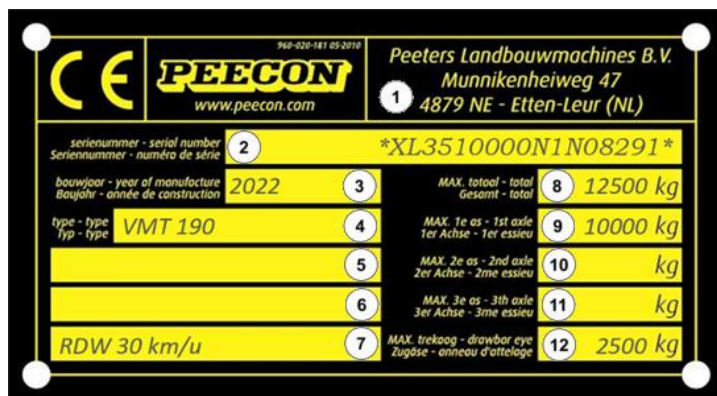



Figure 1 – Type plate

1	Manufacturer contact information	7	Reserved for additional information
2	Serial number (identification number)	8	Maximum total weight of the machine
3	Year of manufacture	9	Maximum axle load on the 1st axle
4	Machine configuration	10	Maximum axle load on the 2nd axle (if applicable)
5	Reserved for additional information (e.g., homologation number)	11	Maximum axle load on the 3rd axle (if applicable)
6	Reserved for additional information	12	Legal maximum drawbar load (varies by country)

2. Technical specifications





Biga Topliner Future	10-221/230	12-221/230	13-197/230	16-197/230	19-197/230	24-221/245
Capacity with rubber extension	m ³ 11	13	15	18	21	26
Capacity without rubber extension	m ³ 10	12	13	16	19	24
Length (A)	mm 4780	4830	6480	6506	6570	7034
Diameter bottom (D) / Width (B)	mm 2210/2300	2210/2300	1970/2300	1970/2300	1970/2300	2210/2450
Loading height (C)	mm 2595	2885	2350	2593	2983	3235
Height incl. rubber extension	mm 2856	3146	2611	2854	3244	3497
Weight	kg 3550	3750	5854	6285	6532	7888
Loading capacity	kg 4000	4800	4800	6400	7600	9600
Required horsepower	hp 60	60	65	70	80	90
Type of tyres / SA	7.00x12 DM	7.00x12 DM	205/65R17.5 DM	205/65R17.5 DM	215/75R17.5 DM	245/70R19.5



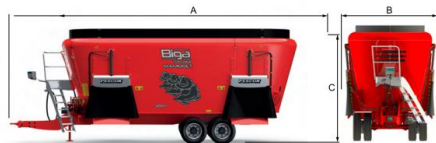

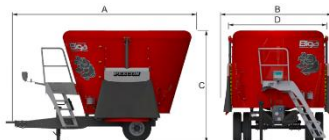

Biga Topliner Mammaet Future	27-197/230	30-197/230
Capacity with rubber extension	m ³ 27	30
Length (A)	mm 8550	8550
Diameter bottom (D) / Width (B)	mm 1970/2300	1970/2300
Loading height (C)	mm 3057	3318
Weight	kg 10125	10260
Loading capacity	kg 10200	12000
Required horsepower	hp 120	120
Type of tyres / SA	215/75R17.5 DM	215/75R17.5 DM









Biga Eco Future	6-200	7.5-200	10-200	10-230	12-230	14-230
Capacity	m ³ 6	7.5	10	10	12	14
Length (A)	mm 4230	4333	4410	4420	4484	4639
Width (B)	mm 2280	2280	2280	2580	2580	2580
Height (C)	mm 2330	2584	2880	2600	2880	3129
Diameter Bottom (D)	mm 2000	2000	2000	2300	2300	2300
Weight	kg 3060	3080	3820	3452	4180	4248
Loading capacity	kg 2500	3000	4000	4000	4800	5600
Required horsepower	hp 50	55	60	65	75	90
Type of tyres / SA	7.00x12 EM	7.00x12 EM	7.00x12 EM	7.00x12 EM	7.00x12 EM	7.00x12 EM

Biga Twin Future	12-200	15-200	18-215	20-215
Capacity	m ³ 12	15	18	20
Length (A)	mm 6230	6330	6770	6750
Diameter bottom (D) / Width (B)	mm 2000/2280	2000/2280	2150/2430	2150/2430
Height (C)	mm 2360	2620	2740	2970
Weight	kg 5600	5800	6900	7000
Loading capacity	kg 4800	6000	7200	8000
Required horsepower	hp 75*	80*	85*	90*
Type of tyres / SA	 205/65R17.5 DM	 205/65R17.5 DM	 205/65R17.5 DM	 215/75R17.5 DM

* is required horsepower with reduction gearbox



Biga Twin Future	24-230s	26-230s	25-245s	30-245s
Capacity	m ³ 24	26	25	30
Length (A)	mm 7100	7430	7500	7646
Diameter bottom (D) / Width (B)	mm 2300/2580	2300/2580	2450/2730	2450/2730
Height (C)	mm 3150	3300	3030	3390
Weight	kg 8600	9000	9500	9950
Loading capacity	kg 9600	10600	10000	12000
Required horsepower	hp 95*	105*	110*	120*
Type of tyres / TA	 215/75R17.5 DM	 215/75R17.5 DM	 215/75R17.5 DM	 245/70R19.5 DM

* is required horsepower with reduction gearbox

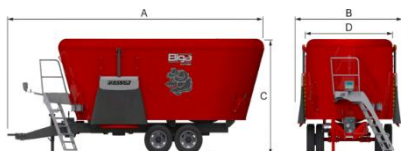





Biga Twin Plus Future		12-200	15-200	18-215	20-215/230 WB
Capacity	m ³	12	15	18	20
Length (A)	mm	7190	7250	7300	7340
Diameter bottom (D) / Width (B)	mm	2000/2300	2000/2300	2150/2290	2150/2330
Height (C)	mm	2410	2670	2790	2850
Weight	kg	5570	5950	7050	7350
Loading capacity	kg	4800	6000	7200	8000
Required horsepower	hp	75*	80*	85*	90*
Type of tyres / SA	 	205/65R17.5 DM	205/65R17.5 DM	205/65R17.5 DM	215/75R17.5 DM



Biga Twin Plus Future		24-230s	26-230s	25-245s	30-245s
Capacity	m ³	24	26	25	30
Length (A)	mm	8020	8070	8420	8640
Diameter bottom (D) / Width (B)	mm	2300/2300	2300/2300	2450/2480	2450/2480
Height (C)	mm	3200	3350	3080	3440
Weight	kg	9400	9550	9920	10300
Loading capacity	kg	9600	10600	10000	12000
Required horsepower	hp	95*	105*	110*	120*
Type of tyres / TA	 	215/75R17.5 DM	215/75R17.5 DM	215/75R17.5 DM	245/70R19.5 DM

* is required horsepower with reduction gearbox



Biga Lowliner		18-197/230	20-197/230	24-221/260
Capacity	m ³	18	20	24
Diameter bottom	mm	1970	1970	2210
Weight	kg	6500	6900	7200
Length (A)	mm	7050	7180	7650
Width (B)	mm	2480	2480	2750
Height (C)	mm	2780	3100	3120
Loading capacity	kg	6800	8000	9600
Type of tyres / SA	 	385/65R22.5	385/65R22.5	375/90R22.5



Biga Twin WB Future		16-200/230	20-215/230	22-215/245
Capacity	m ³	16	20	22
Length (A)	mm	6430	6830	6920
Diameter bottom (D) / Width (B)	mm	2000/2510	2150/2510	2150/2580
Height (C)	mm	2560	2920	2980
Weight	kg	5790	6590	6660
Loading capacity	kg	6300	8000	8800
Required horsepower	hp	80	90	90
Type of tyres / SA	 	205/65R17.5 DM	215/75R17.5 DM	215/75R17.5 DM



Biga Twin WB Future		26-230/260s	28-230/260s	27-245/275s	32-245/275s
Capacity	m ³	26	28	27	32
Length (A)	mm	7250	7270	7670	7700
Diameter bottom (D) / Width (B)	mm	2300/2710	2300/2710	2450/2950	2450/2950
Height (C)	mm	3130	3300	3050	3390
Weight	kg	8510	8660	9400	9980
Loading capacity	kg	10600	11400	11000	12800
Required horsepower	hp	95*	105*	110*	120*
Type of tyres / TA	 	215/75R17.5 DM	215/75R17.5 DM	215/75R17.5 DM	245/70R19.5 DM





Biga Mammoet Future		27-215	30-215	33-215/230 WB	36-230s	38-230/260s WB
Capacity	m ³	27	30	33	36	38
Length (A)	mm	8800	8950	9010	9540	9790
Width (B)	mm	2450	2450	2500	2580	2820
Height (C)	mm	2850	3000	3020	3250	3215
Diameter bottom (D)	mm	2150	2150	2150	2300	2300
Weight	kg	10280	10480	10700	14600	14800
Loading capacity	kg	10200	12000	13200	14400	15200
Required horsepower	hp	125	140	140	150	155



Biga Mammoet Future		40-230s	42-230/260s WB	45-245s	48-245/275s WB	50-245s
Capacity	m ³	40	42	45	48	50
Length (A)	mm	9600	9850	10120	10270	10200
Width (B)	mm	2580	2820	2730	2960	2730
Height (C)	mm	3400	3485	3500	3500	3760
Diameter bottom (D)	mm	2300	2300	2450	2450	2450
Weight	kg	15020	13810	15700	16980	17000
Loading capacity	kg	16000	17000	18000	19200	20000
Required horsepower	hp	165	170	180	185	195



Biga Mega Mammoet HD		52-230s	60-245s	64-245/275s WB	70-245/275s WB
Capacity	m ³	52	60	64	70
Length (A)	mm	12050	12690	12840	12940
Width (B)	mm	2600	2810	2900	2900
Height (C)	mm	3450	3550	3550	3780
Diameter bottom (D)	mm	2300	2450	2450	2450
Weight	kg	20120	21600	22800	28320
Loading capacity	kg	22000	24000	25600	28000
Required horsepower	hp	200	220	240	250



3. Application of the machine

This machine is intended exclusively for the following applications:

- Mixing loaded feed.
- Transporting and distributing the mixed feed.

When using the machine, you must always comply with the instructions in this manual. This applies to both the operating and safety instructions provided by the manufacturer.

When operating the machine on public roads, it must comply with all applicable traffic regulations. For more information, please refer to **Section 6.5 – Lighting**. It is the user's responsibility to be aware of and adhere to local regulations.

Performing any structural modifications or additions without the manufacturer's approval is not permitted. Such modifications can create hazardous situations and may result in serious injury or death.

The machine may only be operated when no persons or animals are present within the hazard zone. It is strictly prohibited to allow persons or animals to ride on or inside the machine.

4. Important safety precautions



CAUTION! Read this manual carefully before operating the machine. Refer to the manual if you have any questions or encounter any issues. Check that the factory settings have not been altered and that no components have become loose during transport. Ensure that all warning labels are present and properly affixed in their designated locations. Always inspect the drawbar eye for any defects before using the machine.

4.1. Algemeen

The driver or operator is always responsible for any damage and/or accidents resulting from improper use or failure to comply with safety regulations.

The feed mixer wagon may only be used for mixing, transporting, and dispensing livestock feed products. Use for any other purpose is not permitted.

Never drive on public roads without properly functioning lighting.



TIP! When driving on public roads, always ensure that you comply with the regulations of the Department of Motor Vehicles. This includes, but is not limited to, maximum axle loads, permitted vehicle dimensions, lighting, and braking requirements.

Before each use, check the following points:

- Carefully inspect the machine for any visible damage and loose components.
- Verify that all connections are securely fastened.
- Ensure that the discharge doors are completely closed.
- If applicable, check the proper functioning of the brakes and lighting.
- Confirm that the support leg is fully retracted.
- Make sure no feed can fall or blow out of the machine.
- Check that the parking brake is disengaged and fully released.
- Ensure that no one is within the machine's working area.
- Never exceed the maximum load capacity and driving speed (as indicated on the identification plate).
- Inspect the wheel nuts and tire pressure.
- Review the safety instructions.



CAUTION! We would like to draw your attention to situations that require extra caution in order to ensure your own safety as well as the safety of others in the surrounding area.

The following situations require extra caution:

- Starting, operating, or test running the machine must never be performed in an enclosed space due to the danger of hazardous exhaust fumes.
- Always check the area around the machine and tractor before driving off or engaging the machine.

- Pay extra attention to people, animals, and especially children in the vicinity.
- Ensure good visibility while working.
- It is strictly prohibited to ride on the machine during transport or operation.
- Never stand between the tractor and the machine unless the vehicle is secured against rolling away (for example, with wheel chocks or the parking brake).
- Stay outside the turning radius and hazard zone of the machine.
- Never enter the mixer wagon. The augers are equipped with extremely sharp blades that can cause severe injury.
- Always verify that the machine is correctly attached to and locked onto the drawbar.

In addition to the instructions in this manual, always observe the generally applicable regulations for safety and accident prevention. Familiarize yourself with all systems, controls, and their functions before operating the machine.

- Before each use, inspect the machine and tractor for safety, both for operation and road transport.
- Read the PTO shaft manual thoroughly before use.
- Always wear close-fitting clothing and avoid loose garments.
- Adjust your driving speed to suit the surroundings and terrain. Never make sudden turns when driving uphill, downhill, or across slopes.
- Keep in mind that mounted and trailed equipment and front weights affect driving behavior, maneuverability, and braking performance. Always ensure sufficient steering and braking capability.
- When turning, consider the increased width (turning radius) and mass of the machine.
- The machine must be operated by one person only.
- Always secure the machine before leaving the tractor: switch off the engine, remove the ignition key, and, if equipped with electric controls, switch off all functions and unplug the power connection.
- Never allow anyone near rotating components while the PTO shaft is engaged.
- Couple the machine according to the instructions and always check that all locking devices are properly secured.
- Be especially careful when coupling and uncoupling due to crushing and pinching hazards.
- Operate only machines with all protective covers complete and intact.
- Repair any paint damage or wear immediately before putting the machine back into service. If the machine is still under warranty, contact your dealer or the manufacturer first.
- Regularly check that hydraulic hoses are undamaged. Replace damaged hoses immediately with hoses of the specified quality (SAE 100 R2A according to DIN 20022/2).
- Never attempt to seal a leak in an operating hydraulic system by hand. Oil can penetrate the skin and cause blood poisoning.

- Always check the direction of rotation and the speed of the PTO shaft before engaging it. If these do not match the required settings (refer to the decals), adjust them accordingly.



CAUTION! Pay attention when attaching the machine to the tractor for the first time. This will help prevent hydraulic functions from operating incorrectly or failing to operate.

- Clean, lubricate, or adjust machines driven by a drive shaft and the drive shaft itself only when the PTO is disengaged, the engine is turned off, and the ignition key has been removed.
- The operator's seat must be occupied at all times while driving and operating the machine.
- When transporting on public roads, comply with all legal regulations, including lighting and (side) reflectors.
- Always check the permitted transport dimensions.
- Disengage the PTO when it is not needed to avoid unnecessary degradation of the oil.
- Inspect the auger knives and bolts weekly to ensure they are not excessively worn. Loose knives in the feed can cause hazardous and inhumane situations for animals.

4.2. Danger zone

During operation, no persons are permitted within the danger zone.

- Sides: Maintain a minimum distance of 5 meters.
- Front and rear: Maintain a minimum distance of 10 meters.

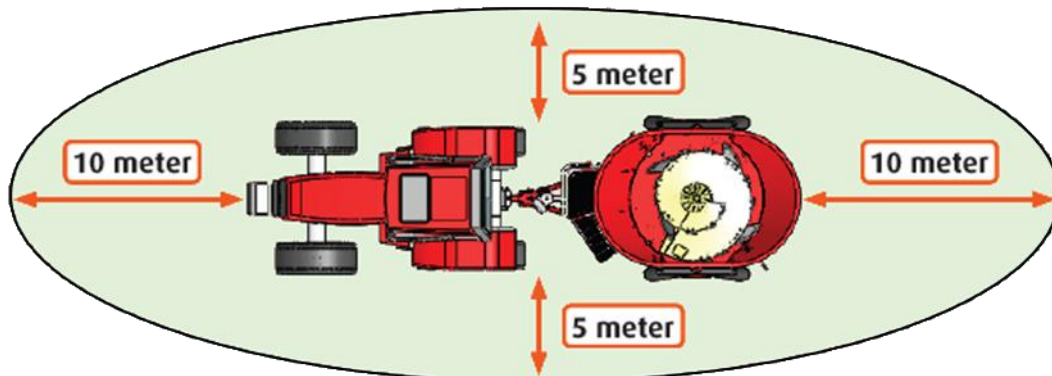

Figure 2 - Danger zone



CAUTION! It is strictly prohibited to step onto the platform while operating, loading, or unloading the mixer wagon.

The machine operates within a noise level of **70 dB(A)**. Hearing protection is not strictly required but may be recommended depending on ambient noise levels. Always ensure that hearing protection is available.

4.3. Attaching and detaching the machine

Important safety regulations:

- Attach the machine according to the prescribed procedures.
- Use only tractors that are suitable for operating and transporting the machine.
- Never exceed:
 - The maximum permitted axle load.
 - The maximum drawbar load on the tractor hitch.
 - The maximum allowable total weight of the tractor.
- Always secure the machine against rolling before detaching it.
- Set the support leg in the correct (safety) position when attaching and detaching.
- Pay extra attention to crushing and pinching hazards between the tractor and the machine, especially during coupling.
- Check if connected hoses:
 - Do not rub against sharp or moving parts.
 - Have sufficient freedom of movement when turning.

4.4. Operating the machine

- Wear close-fitting clothing. Loose clothing increases the risk of entanglement.
- Familiarize yourself with all components and operating functions before starting work.
- Never exceed the maximum permissible total weight, axle load, or drawbar load.
- Operate the machine only when all protective covers and safety devices are correctly installed and closed.
- Do not allow any persons in the vicinity of the machine during operation.
- Always secure the tractor against unintended starting or rolling before leaving it.

4.5. Safety symbols

Your mixer wagon is equipped with decals displaying safety and warning indications. These identify areas where risks are present despite the machine's safe design.

Always read the manual before putting the machine into operation. Regularly check that all decals are present and clearly legible. If any decals are damaged or illegible, do not continue working and have them replaced by your dealer.



CAUTION! To ensure that every (new) operator can work safely, all decals must always be clean and clearly legible. If any decals are damaged, they must be replaced without exception.

Replacement decals are available from your dealer.

4.5.1. Explanation of safety symbols



Before commissioning, read and observe the manual and safety instructions.



These hoses can cause personal injury and environmental damage. Work on the hydraulic system only when it is completely depressurized.



Retighten the wheel nuts after the first hour of operation and then every 25 operating hours to 310 Nm, and check the tire pressure.



It is prohibited to stand on or underneath the machine while it is operating or moving. During loading, no one is allowed to stand behind the mixer wagon.



It is strictly prohibited to climb onto or step onto the platform. Do not allow anyone to load the machine manually from the platform (risk of falling in).



Check the lubrication points every 10 operating hours to prevent wear and high repair costs. Use the specified type of grease. If in doubt, contact your dealer.



It is not recommended to compress the load inside the mixing chamber. Doing so may cause damage or malfunctions to the tractor or the machine.



Keep a safe distance from rotating parts. Always switch off the machine and remove the ignition key before performing any maintenance.



Driving forward with the PTO engaged is permitted. Reversing is only allowed with the PTO disengaged, unless a reversible PTO is used (pay attention to the direction of rotation).



Risk of entanglement and cutting hazards near the mixing chamber. Stay away from the discharge opening. Always remove the ignition key and disconnect the PTO before performing any work.



Touching rotating shafts and wearing loose clothing create a risk of entanglement and being pulled into rotation with the shaft.

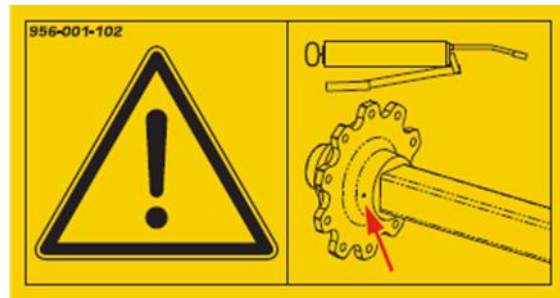

If your mixer wagon is equipped with axles, there may be a lubrication point on the axle hub.



Never stand inside the loading tailgate of the mixer wagon. Falling or becoming trapped can cause serious injury.



Use the step only when the loading tailgate is completely closed and the feed mixer is stationary.



Keep a safe distance from the moving loading tailgate. Body parts can become trapped.

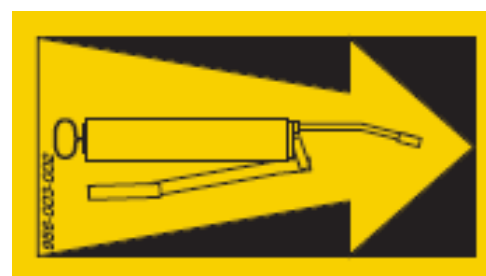

One or more lubrication points are located here. Lubricate them according to the maintenance schedule.



Ensure that the oil level in the planetary gearbox is visible in the upper sight glass (applicable only to models with a steel oil reservoir).



Ensure that the oil level in the planetary gearbox is above the minimum and below the maximum level (applicable only to models with a transparent plastic oil reservoir).



This is a lifting point. Use only these points to lift the machine.



Not a lifting point. Do not attach cables, chains, or any other lifting equipment here. Doing so may cause damage to the machine.



The position of the loading tailgate can be read from the tractor on the drawbar, using the indicator rod and the corresponding decal. Position "0" indicates that the tailgate is fully lowered. The displayed value, multiplied by 6, indicates the opening angle in degrees. For example, position 15 means the tailgate is at an angle of 90 degrees and therefore closed.



The position of the (front) discharge door(s) can be read on the side of the tub via the indicator and the corresponding decal. At position "0," the door is closed; at position "9," it is fully open.



The position of the rear discharge door(s) can be read on the front of the tub via the indicator and the corresponding decal. At position "0," the door is closed; at position "9," it is fully open.

4.5.2. Safety symbols on the machine



Figure 3 - All possible safety symbols



Figure 4 - Safety symbols - Topliner



Figure 5 - Safety symbols - Mammoet



Figure 6 - Safety symbols - Twin Plus

4.6. Brake system

The tractor's brake system must be compatible with the brake system of the machine. If the machine indicates a malfunction, immediately stop the towing vehicle and have the issue resolved.

Repairs and adjustments to the braking system must only be carried out by qualified experts and specialists. For this reason, have the system inspected regularly to avoid unplanned downtime.

Maintenance: Lubricate all grease fittings at least every 50 operating hours. If your machine is equipped with a manually braked axle, test it regularly by pulling the brake lever (the wheels must lock). This system must also be lubricated every 50 working hours.

Note: When performing work near the braking system (e.g., grinding, welding, or drilling), always protect critical components carefully to prevent damage.

4.7. Extreme conditions

This section describes extreme situations. If you encounter these conditions, be aware that the system may not function correctly.

The recommended operating and ambient temperature range is between -30 °C and +40 °C.

When operating at lower temperatures:

- Wear of hydraulic seals increases.
- The risk of damaged hydraulic hoses and brittle fractures in the steel structure is higher.
- Important precaution: Load the machine only with lighter loads than normally permitted.

Before operating at low temperatures:

- Allow the oil to circulate through the system for several minutes.
- Perform all functions slowly several times to allow the seals to become supple before they are subjected to full pressure.

When operating in extremely warm conditions:

- Be aware that the hydraulic oil can become very hot.
- If the oil temperature exceeds +80 °C, the oil may begin to evaporate, and seals may become damaged.

5. Machine operation

The various feed components are loaded into the machine. The sequence and speed of loading are essential for achieving an effective mixing process.

Inside the mixing chamber, the feed is reduced in size by the cutting action of the knives mounted on the rotating auger. Depending on the structure of the components, additional counter knives on the outer wall of the mixing chamber can be engaged to accelerate the cutting process.

Due to the shape and rotation of the auger, the feed is conveyed upward and then guided back down along the wall of the mixing chamber. Filling the chamber to approximately 90% of its capacity results in the most efficient mixing performance.

Once the mixing process is complete and a homogeneous mixture has been achieved, the feed can be discharged. To do this, drive the machine along the feed fence at a constant speed, allowing the feed to be distributed evenly.

The quantity of the discharged mixture can be adjusted from the towing vehicle by moving the discharge slides up or down until the desired amount is reached.

Depending on the configuration, the machine is equipped with a discharge conveyor that directs the feed to either the left or the right side of the machine.

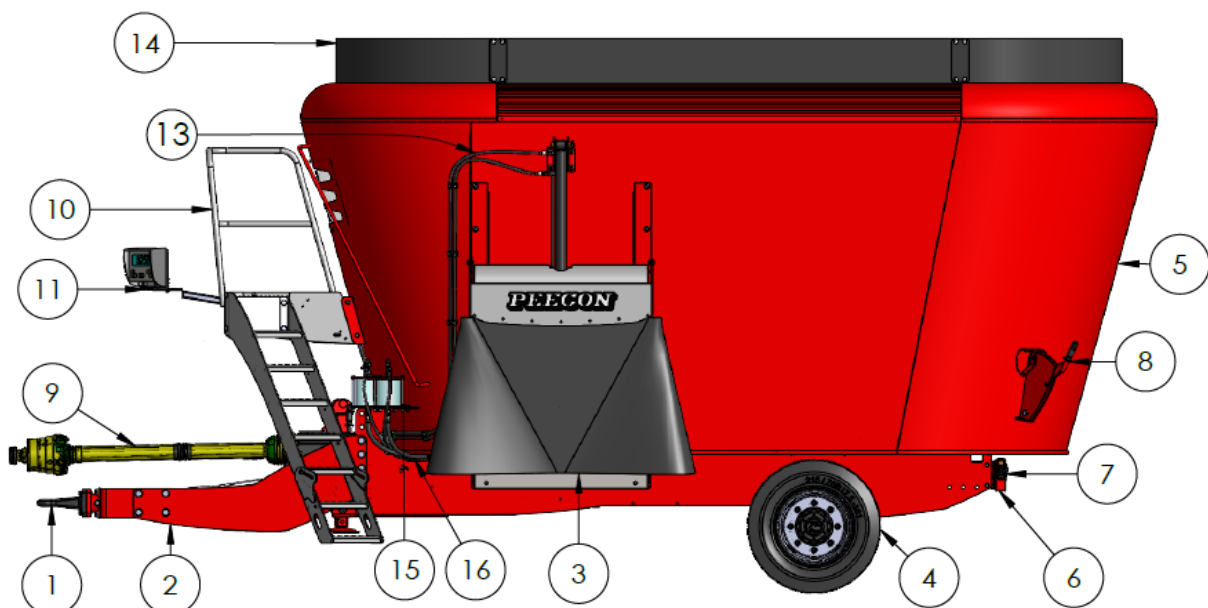

1	Drawbar eye	7	Camera (option)	13	Hydraulic hoses for discharge door
2	Drawbar (top attachment)	8	Counter-knife control lever	14	Extension rim (option)
3	Discharge door with door seal	9	PTO shaft	15	Oil reservoir for auger drive
4	Axle (number depending on model)	10	Steps and platform	16	Oil lines for auger drive
5	Mixing chamber	11	Display and control panel for weighing system		
6	Lighting bar (option)	12	Hydraulic cylinder for discharge door		

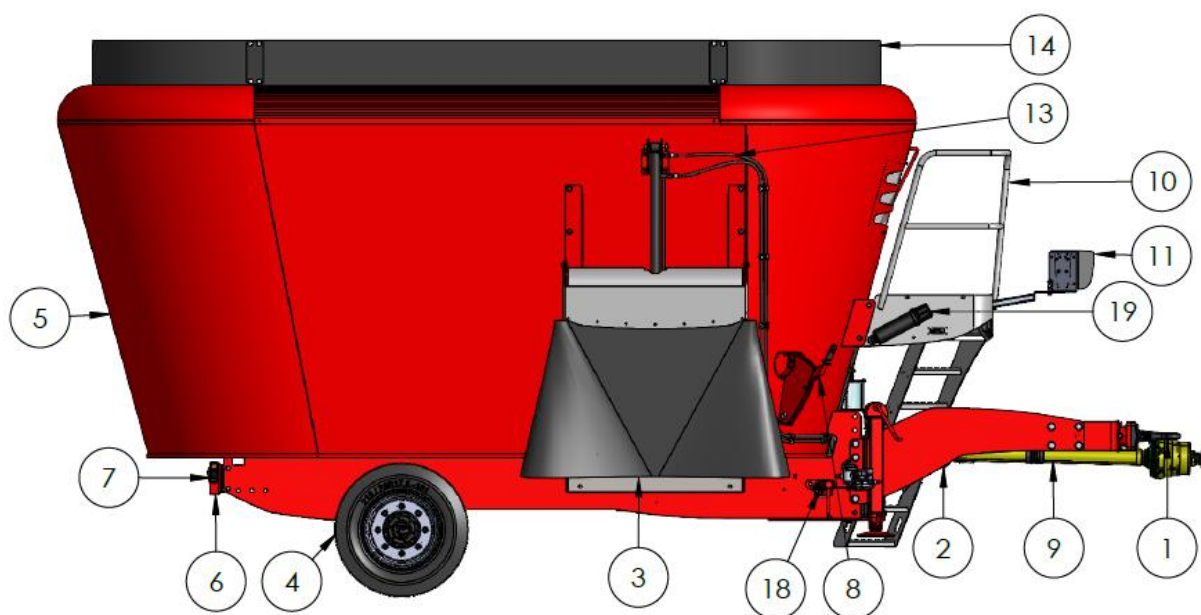

1	Drawbar eye	7	Camera (option)	13	Hydraulic hoses for discharge door
2	Drawbar (top attachment)	8	Counter-knife control lever	14	Extension rim (option)
3	Discharge door with door seal	9	PTO shaft	18	Parking brake
4	Axle (number depending on model)	10	Steps and platform	19	Document holder
5	Mixing chamber	11	Display and control panel for weighing system		
6	Lighting bar (option)	12	Hydraulic cylinder for discharge door		

6. Initial commissioning

6.1. Chassis

Depending on the configuration of your machine, the number of augers, chassis type, number of axles, drive system, and discharge method for the feed mixture may vary.

A Biga feed mixer can be equipped with one, two, or three augers. There are two different types of augers (see Chapter 9.4 – Augers).

The chassis configurations are divided into two groups:

Self-supporting chassis

A self-supporting box-section chassis on which the tub is mounted. The entire tub, including the auger drive, rests on 4 to 10 load cells, depending on the size of the tub.



This chassis is available with:

- a single axle,
- tandem axles (walking beam),
- triple axles (optionally with hydraulically steered axles).

Topliner / Lowliner chassis

In this configuration, the chassis is integrated into the tub construction, resulting in a lower center of gravity.

The load cells are positioned as follows:

- two load cells between the axle mounts,
- one load cell at the drawbar eye, resulting in a total of 3 or 5 load cells.



6.2. Drawbar

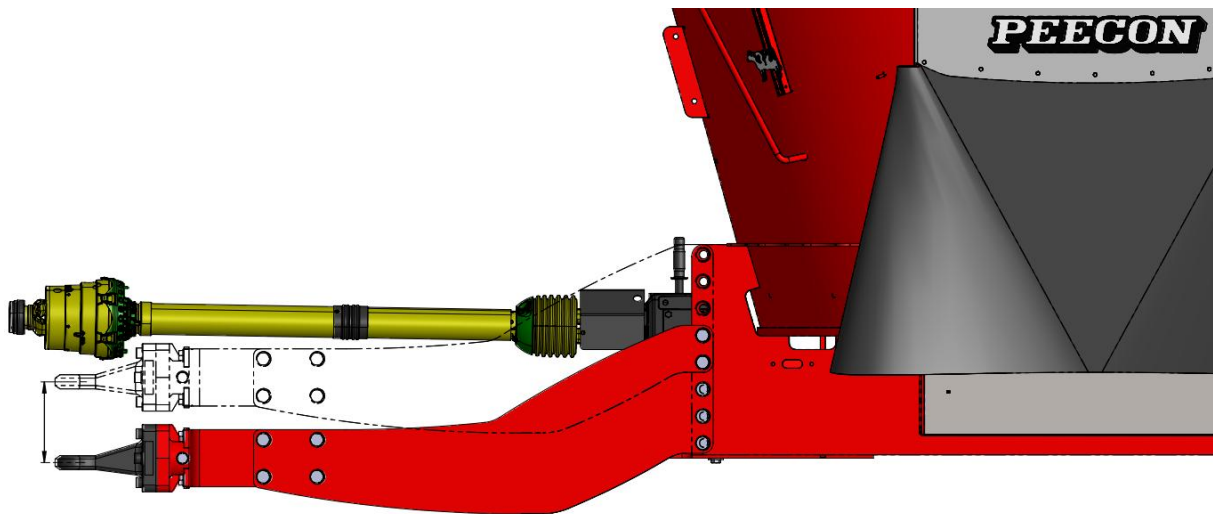

Figure 7 - Drawbar

Before putting the machine into operation for the first time, the height of the drawbar must be set correctly.

When the towing vehicle and the attached machine are on level ground, the machine must be positioned horizontally. This is essential for accurate measurement of the load weight.

Use all bolt holes (5 bolt connections per side, 10 in total) and tighten the bolts to the specified torque (see Chapter 9.10 – Wheel Nuts, Chassis Bolts).



CAUTION! Ensure that the load cell is always installed in the correct orientation.

6.3. Drawbar eyes

A drawbar eye connects the feed mixer to the towing vehicle. Inspect this component for defects before each use.

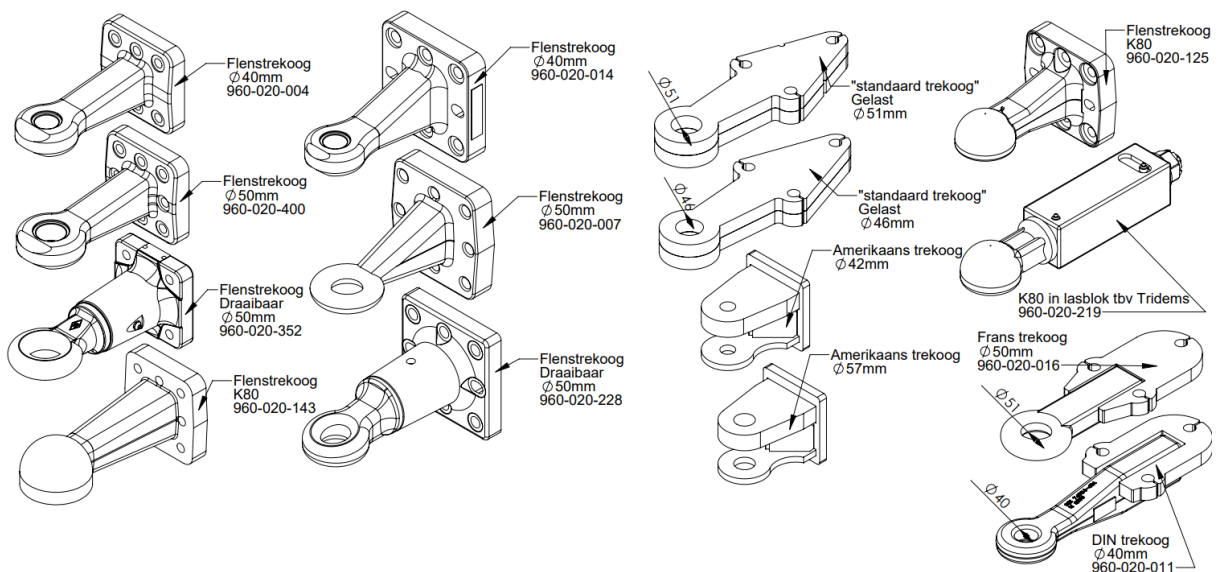

Figure 8 - Drawbar eyes

6.4. PTO shaft



CAUTION! Use only a PTO shaft with a guard that is complete, intact, and secured against rotation. Always check that the PTO shaft is correctly installed.

To drive the mixer wagon, the towing vehicle must be equipped with a PTO (Power Take-Off). The machine is connected to the PTO using the supplied shaft.

1. After coupling, check the length of the PTO shaft. The outer tube must have at least 15 cm (6 inches) of sliding clearance remaining. If necessary, shorten the PTO shaft as follows:
2. Pull the shaft halves apart and place them side by side in the shortest operating position between tractor and implement.
3. Mark the outer guard tube to the correct length.
4. Remove the guard tubes and cut off the marked section.
5. Shorten the inner guard tube to the same length.
6. Shorten the outer and inner profile tubes to the same length as the removed guard section. Make sure the cuts are straight, deburr them, and clean thoroughly.
7. Lubricate the inner profile.

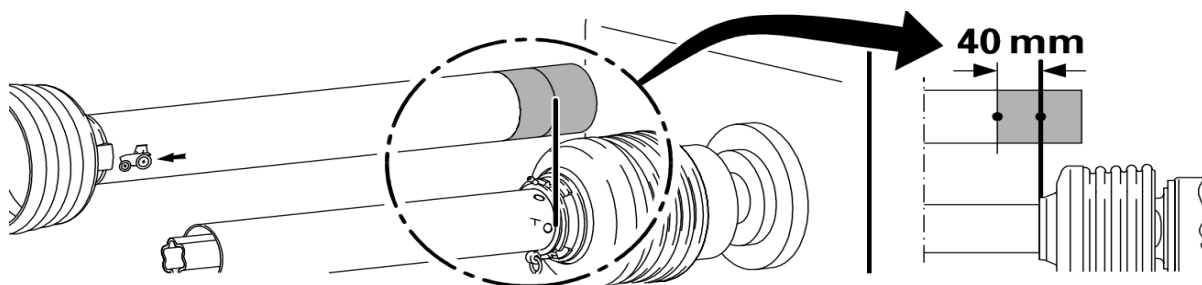

Figure 9 - PTO shaft

When a PTO shaft is equipped with a shear bolt, it must be installed on the machine side. Before assembly, clean all components and apply grease.

6.5. Lighting

To drive the machine on public roads, it must be equipped with the required lighting and reflectors. These components are available as optional equipment. Below you will find the plug layout.

Pin	Color	Function
L	Yellow	Left turn signal
54G	Blue	12V
31	White	Ground
R	Green	Right turn signal
58R	Brown	Right side lighting
54	Red	Brake light
58L	Black	Left side lighting

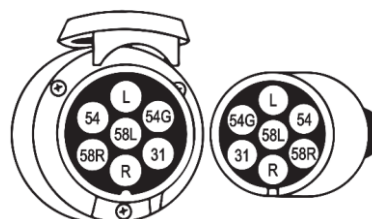

Figure 10 - Plug

6.6. Hydraulic hoses

The hydraulic hoses connected to the tractor are color-coded. Below you will find the corresponding functions.

Color	Function
1x Green	Support leg
1x Black	Brake
1x White	Suspension
2x Red	Pressure valve
2x Blue	Return
1x Green/ 1x White	Load sense
2x Black	Leakage line
2x Green	Rear tailgate/option

7. Attaching and detaching

When operating any machine, it is essential that the combination of the tractor and the attached equipment complies with both the manufacturers' operating and safety instructions and all applicable local laws and regulations. It is the user's responsibility to verify that this is in order.

The machine may only be operated by qualified individuals who have read and fully understood the operating and safety instructions. Do not involve unqualified persons in coupling, uncoupling, or operating the machine.

It is strictly prohibited to stand between the tractor and the machine while the tractor engine is running.

Always check before approaching the machine that it is positioned on a stable, solid surface and that the parking brake is engaged.

7.1. Attaching



CAUTION! Switch off the engine and remove the ignition key from the towing vehicle before connecting the PTO shaft. No persons should ever be between the towing vehicle and the machine while the engine is running.

- **Adjust the drawbar height:** If your machine is equipped with a manual support leg, the height can be adjusted manually. For a hydraulic support leg, first connect the hydraulic hoses, then adjust the height by operating the tractor valve.
- **Attach the drawbar:** Reverse the tractor up to the drawbar and connect it. Then secure the drawbar pin.
- **Connect the hydraulic hoses.**
- **Connect the brake lines:** Depending on the axles installed on your machine, these will be either hydraulic or pneumatic lines. Ensure the braking system is always correctly connected when the machine is coupled.



CAUTION! Use only a PTO shaft with guards that are complete and undamaged. Do not wear loose clothing near moving parts.

- **Connect the steering rod:** If your machine is equipped with steering axles, connect the steering rod to the towing vehicle.
- **Connect the PTO shaft:** Ensure the PTO transfers power from the tractor to the machine at a minimal angle. Combined with proper maintenance, this will extend service life.
- **Connect the control cable:** If applicable, connect the control cables for shifting the reduction gearbox to the control unit in the tractor cab.
- **Connect the electrical supply:** Provide power to the electrical components by plugging in the connector on the tractor.
- **Raise the support leg fully:** Make sure the support leg is lifted high enough that it does not contact curbs or uneven surfaces.
- **Release the parking brake:** Operate the parking brake lever to disengage it. Ensure the parking brake is fully released and does not drag during operation.

PTO shaft

Installing the PTO shaft at minimal angles will extend its service life. Avoid angles greater than 25° when the PTO is engaged. A shorter overall length is also beneficial for longer durability.

Note: When the PTO shaft is fully extended, at least one-third of the profile tubes must remain overlapped. For instructions on shortening the shaft, see Chapter 6.4 – PTO.

Control cable (optional)

As an option, the machine can be equipped with a control box with Bowden cables. This allows shifting the transmission between the PTO and the augers from the tractor cab.

Mount the control lever in an easily accessible location inside the cab, but in such a way that it cannot be operated accidentally, for example, when entering or exiting the cab. Make sure the cables do not drag on the ground or become entangled during turns.

Service brake (hydraulic or pneumatic)

Always connect the brake coupling as soon as the machine is attached. Depending on the configuration, the machine is equipped with a hydraulic or pneumatic (air) brake system.

Then connect the remaining couplings, such as the lighting plug and hydraulic hoses. Verify that all connections are correctly attached. Note: Connecting a hydraulic hose to the wrong coupling can cause damage.

When the machine is fully coupled and secured, the parking brake can be released. This is done using the lever on the front of the machine (see Fig. 7-1).

7.2. Detaching

Only detach the machine when it is empty. The weight of a fully loaded machine is too great to be supported by the ground. In addition, restarting the augers can be difficult if feed has remained inside the machine for an extended period.

Make sure the machine is parked in a safe location where it does not create an obstruction. Always park on a stable, solid surface and engage the parking brake.

Park the machine on a stable, level surface in a place where it does not pose an obstacle. Engage the tractor's parking brake and switch off the engine.

Detaching procedure

- Park the machine on a stable, level surface in a location where it does not create an obstruction.
- Engage the tractor's parking brake and switch off the engine.
- Engage the machine's parking brake.
- Lower the support leg until the drawbar lifts free from the hitch.
- Pull out the locking pin (1) and locate the hole where the support leg is almost touching the ground (3). Then turn the leg further downward using the handle (4) so the drawbar is fully released. (For hydraulic support legs, this is done via the tractor valve.)
- Disconnect the hydraulic hoses and the lighting plug from the tractor.
- Remove the drawbar pin and carefully drive the tractor away from the machine.

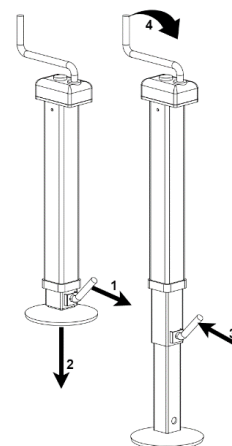

Figure 11 - Parking brake

8. Operating the machine

Always check before using the machine that it is in proper working condition. Verify that the machine is correctly coupled and secured, that all hydraulic hoses and the electrical plug are properly connected, and that the brakes and lighting are functioning correctly. Also check the oil level and look for any damaged components. When you are ready to start, release the machine's parking brake.

For safe operation, pay special attention to the following points:

- Inspect the entire structure for visible cracks or deformations.
- Check if the discharge doors function properly.
- Test the controls together with the hydraulic valve block for any defects.
- Inspect hydraulic hoses and lines for leaks, pinching, or damage.
- Check the hydraulic cylinders for leaks.
- Examine the rubber flaps at the discharge door for signs of cracking.
- Ensure there is sufficient oil in the hydraulic system.
- If applicable, check the operation of the discharge conveyor.
- Inspect all bolt connections on and around the auger.

Note: Never operate the machine when people or animals are within the hazard zone. The machine must only be operated by one qualified person. It is strictly prohibited to step onto the platform while the PTO is engaged.

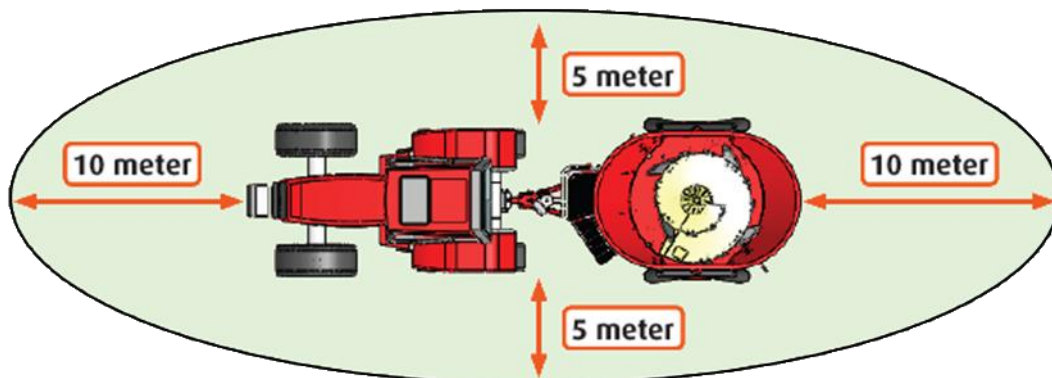

Figure 12 - Danger zone



CAUTION! Always engage the parking brake and disengage the drive to the machine before leaving the tractor.



CAUTION! Do not operate the machine in an enclosed space. Inhaling exhaust fumes can cause health problems.

8.1. Operation

By default, the hydraulic functions of the machine are controlled via the tractor's control valves. Optionally, the machine can be equipped with an electric control terminal, which allows up to six functions to be operated. The exact functions depend on the configuration and specification of your machine.

If your machine is equipped with a control box, the functions can be operated using the lever on this box. Optionally, a Bowden cable is available, enabling the control box to be operated from inside the tractor cab.

8.2. Loading

Always position the machine on a flat, stable, and solid surface before loading. Make sure no people are present in the immediate area and that there is sufficient space to maneuver the second machine used for loading the feed components.

Never fill the mixing chamber completely to the top. This causes excessive load on the drive system and reduces the quality of the mixing process. The exact chamber height depends on the model you are using. During loading, ensure that the attachment does not come into contact with the augers or the mixing tub.

During loading, engage the transmission in the lowest gear reduction and limit the PTO input speed to a maximum of 400 rpm. Allow the augers to turn slowly while you add the feed components. Large quantities of feed, such as whole bales, should not be tipped in all at once but in portions. This reduces the required power and saves fuel. Always tip the feed gradually and from the lowest possible height to minimize peak loads on the augers.

8.3. Loading sequence

For an efficient mixing process, lighter components should be loaded first and the heaviest components last. This allows the heavy materials to settle more quickly through the mixture. In practice, however, it may be desirable to deviate from this order, for example when using special feed components.

The sequence below serves as a general guideline:

1. Start by loading long or lighter, fibrous products such as hay.
2. Then add concentrates or pellet feed.
3. If applicable, minerals can be added at this stage.
4. Next, load grass silage.
5. Then add corn and/or grain silage.
6. Finish with high-moisture products such as brewers' grains, beets, or citrus pulp.
7. If needed, liquid components like molasses can be added last.



CAUTION! Never disengage the reduction gearbox while the augers are still rotating. Doing so can cause damage to the drive system. Disengaging while the augers are turning is only permitted if the machine is equipped with a powershift.



TIP! Position the tractor directly in front of the machine during loading and mixing. A minimal PTO angle will extend service life.

8.4. Mixing

The duration of the mixing process depends greatly on the composition of the feed mixture. The guideline below can be adjusted based on experience to achieve optimal results:

1. **Mixing Time:** After loading the feed components, allow the machine to mix for an additional 5–8 minutes until a homogeneous mixture is achieved. If your machine is equipped with a wide-angle PTO shaft, mixing can also be performed during transport.
2. **Counter Knives:** Engage the counter knives if needed to increase cutting intensity.
3. **Speed:** Adjust the auger speed by shifting the reduction gearbox or changing the PTO speed. During mixing, the augers should operate at 20–30 revolutions per minute.

8.5. Discharging

1. Engage the PTO so the augers begin rotating.
2. Engage the discharge conveyor (optional) in the correct direction of rotation.
3. Open the discharge door. By adjusting the height of the slide, you control the discharge rate. The height can be read on the indicator.
4. Select the appropriate combination of driving speed and discharge speed to distribute the feed evenly.
5. When the mixing chamber is nearly empty, the auger speed can be increased to remove the remaining feed.
6. Switch off the discharge conveyor (optional).
7. Gradually reduce the PTO speed before disengaging it completely.
8. Fully close the discharge door.



CAUTION! Abruptly stopping the augers can cause damage to the drive system. Always reduce speed gradually before fully disengaging the drive.

9. Maintenance of the machine and personal protective equipment (PPE)



Timely and properly performed maintenance is essential for the correct operation and long service life of the machine. Always use the prescribed personal protective equipment (PPE) when performing maintenance.

Before carrying out any maintenance, cleaning, or repair work, ensure that at least the following safety measures and PPE requirements are met:

- The tractor ignition is switched off and the key has been removed.
- The machine is parked on a stable, level surface and secured against rolling away.
- The parking brake is engaged, and the PTO shaft is disconnected.
- The pressure in the hydraulic system has been released.
- A safe working environment has been established.
- You are wearing appropriate personal protective equipment: work gloves, safety glasses, and safety shoes.

All work may only be performed by qualified personnel who have read and understood all operating and safety instructions.

9.1. Maintenance intervals

○ = inspect/lubricate/top up ● = replace	Before each use	Every week	First 10 hours	First 150 hours	Every 8 hours	Every 25 hours	Every 50 hours	Every 100 hours	Every 250 hours	Every 1000 hours	Every year
1: Check for damage or excessive wear	○										○
2: Lubricate wheel bearings									○		○
3: Lubricate universal joints of drive shafts								○			○
4: Inspect hydraulic hoses/lines		○									○
5: Retighten bolts and nuts			○						○		
6: Lubricate PTO shaft							○				
7: Gearbox oil			○	●			○			●	●
8: Powershift oil			○	●			○			●	●
9: Planetary auger oil	○		○	●			○			●	●
10: Grease fittings					○						
11: Retighten wheel nuts			○						○		
12: Visual inspection of auger knives		○							○		
13: Hydraulic oil			○							●	●
14: Drain moisture from air brake system (if equipped)		○									
15: Clean discharge conveyor (optional)		○									
16: Remove contamination from hydraulic components							○				

9.2. Fluid specifications

	Type	Quantity	Article number
Gearbox oil	ISO VG 220	± 11 Liter	959-181-025
Zuidberg powershift oil incl. cooler	ATF	± 8,5 Liter	959-181-032
Allison powershift oil incl. cooler	ATF	MT 20 Liter HT 26 Liter	959-181-032
Planetary auger oil	ISO VG 220	± 20 Liter	959-181-025
Planetary auger oil (7T09RA)	ISO VG 320	± 20 Liter	959-181-051

9.3. Auger drive line

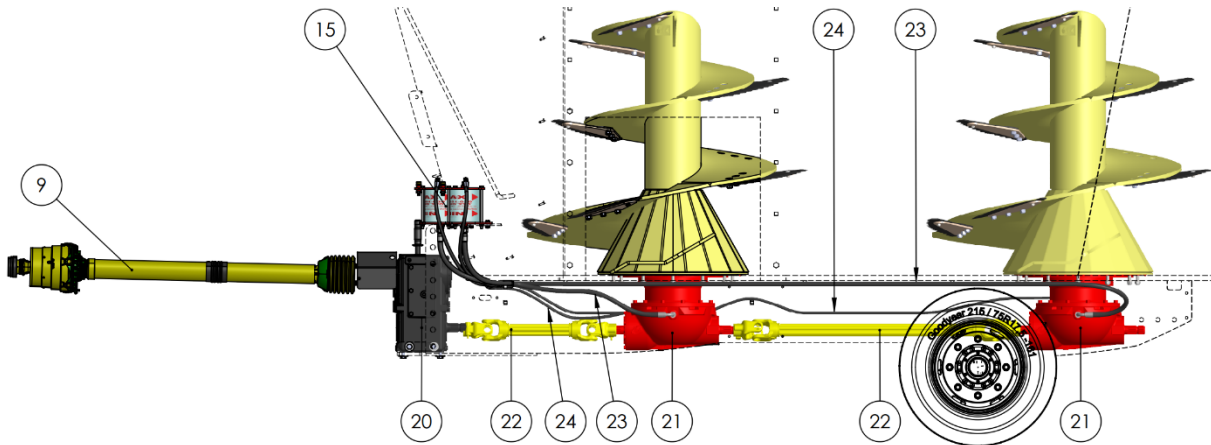
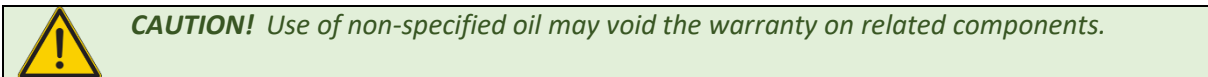

Figure 13 - Augers

9	PTO shaft	22	Drive shaft
15	Oil reservoir for auger transmission	23	Transmission oil supply line
20	Manual reduction gearbox	24	Transmission breather
21	Auger transmission	25	Drain plug



9.3.1. Planetary reduction gearboxes

Oil type	Synthetic oil EP220
Oil quantity per auger transmission	± 20 Liter
Service interval	See maintenance interval table (9.1)

The gearbox (21), to which the augers are mounted, is filled with synthetic oil. This oil provides lubrication for the gears and bearings.

The oil must be replaced at least once every 2 years or after a maximum of 1,000 operating hours, according to the maintenance interval. Regularly check the oil level: it must never fall below the indicated minimum. Top up the oil as soon as the level in the reservoir approaches this mark.

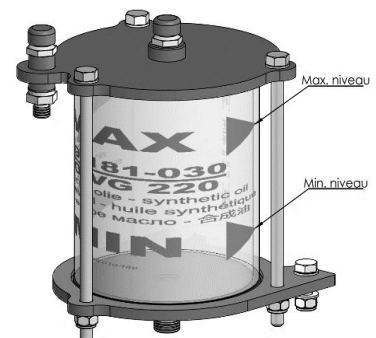

Figure 14 - Gearbox

For augers of the second type (see Section 9.4.2 Auger Type 2), the sliding bearing at the top of the assembly is lubricated with grease. This is done via a grease line. The grease fitting for this is located on the front left side of the machine.

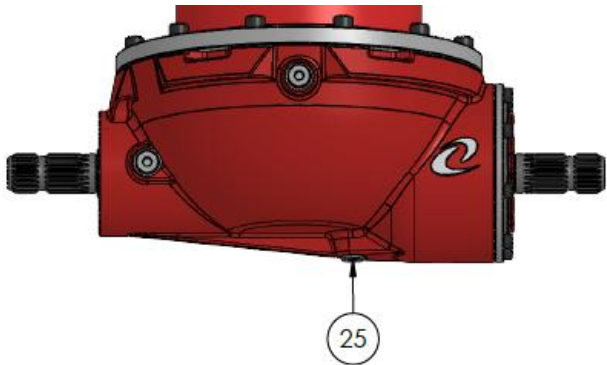

Figure 15 - Planetary drive gearbox $i = 21.10$

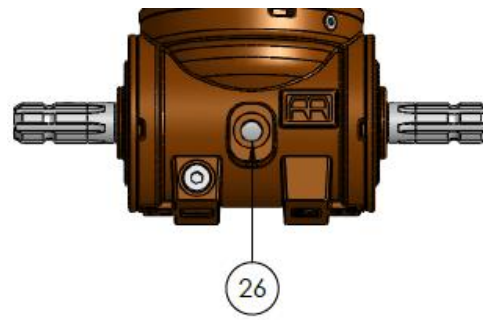

Figure 16 - Gearbox RR1800

Both types of planetary reduction gearboxes are equipped with a drain plug (25/26/27/28/29) on the underside. This plug is used to drain the old oil when replacing the oil.

First, allow all of the oil to drain completely from the gearbox. Then, blow any remaining oil out of the lines using compressed air. Make sure to collect and dispose of the used oil in accordance with applicable local regulations.

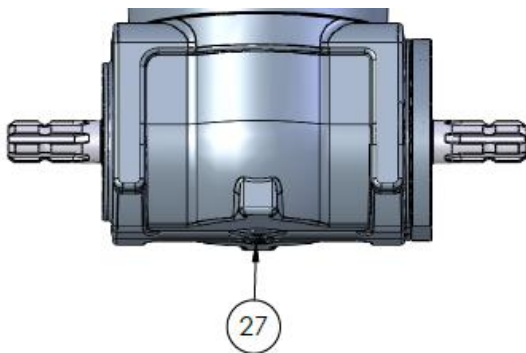

Figure 17 - Planetary drive gearbox EC3320/FE $i = 19.95$



Figure 18 - STM EXBS 1503FS $I=20,6$

Then refill the system with the specified amount of oil. Make sure the reduction gearbox is completely filled and no air remains trapped at the top. You can check this by connecting a vacuum pump to the breather hose on top of the reduction gearbox. Once oil starts to flow through the hose, the gearbox is fully filled.



CAUTION! If the specified oil is not used, the warranty on related components may be void. For the 7T09RA planetary reduction gearbox, the use of synthetic oil ISO VG 320 is mandatory.

Planetary reduction gearbox 7T09RA

Oil type	Synthetic oil ISO VG 320
Oil quantity per auger transmission	± 20 Liter
Service interval	See maintenance interval table (9.1)

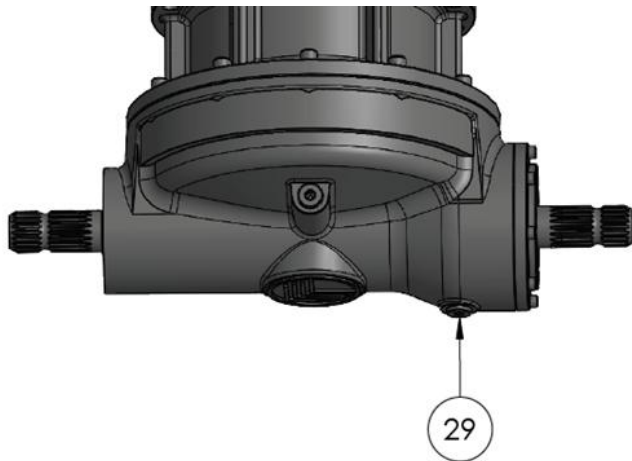

Figure 19 – Drive gearbox 7T09RA i=218

9.3.2. Manual transmission (option)

The manual transmission (20) at the front of the machine is lubricated with the same oil used for the auger transmission. If your machine is equipped with an operating cable or Bowden cable, the transmission can also be operated from the tractor cab. Always shift the transmission only when the PTO shaft is stationary. This does not affect the maintenance of the gearbox.

Oil type	Synthetic oil EP220
Oil quantity	11 Liter
Service interval	See maintenance interval table (9.1)

9.3.3. Drive shafts

The drive gearboxes are interconnected by a drive shaft. The number of drive shafts on the machine depends on the number of augers installed. The universal joints at both ends of the shafts (22) must be lubricated with grease every 100 operating hours.

Type of grease	Kratos EP3
Service interval	See maintenance interval table (9.1)

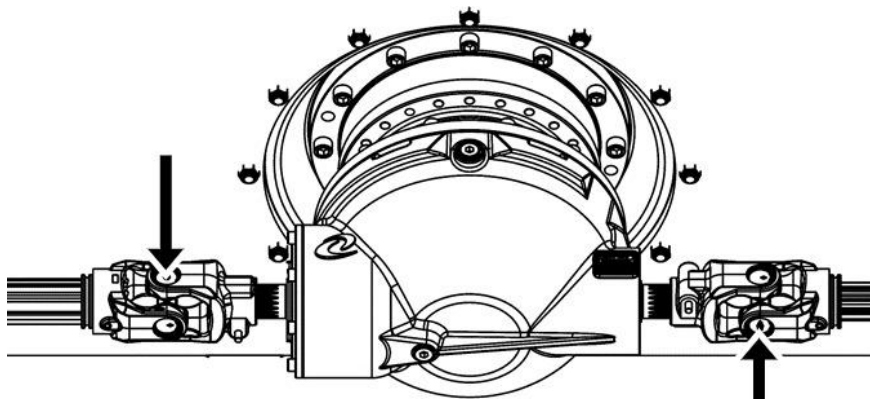

Figure 20 – Lubrication points

9.4. Augers



CAUTION! Always remove the ignition key from the tractor and disconnect the PTO shaft before entering the mixing chamber. Secure the machine against rolling and make sure no one can start or move the machine.

The auger knives are sharp and can cause serious injury. Therefore, always wear appropriate personal protective equipment. Cover the cutting edges of the knives before performing any work inside the mixing chamber. **Note:** If the machine is equipped with magnets (3), tools and other metal objects may be attracted. Electronics can also be damaged by the magnetic field.

Once the machine has been properly secured, work inside the mixing chamber can be carried out. To enter the mixing chamber, fully open one of the discharge slides. This slide must then be locked or blocked to prevent it from closing unexpectedly. Always ensure that a second person remains outside the machine to pass materials and provide assistance in case of emergency.

9.4.1. Auger type 1

The auger of this type is mounted on the planetary reduction gearbox located at the bottom of the machine. All bearings are housed within this gearbox and are lubricated by a lubrication system (see section 9.3.1).

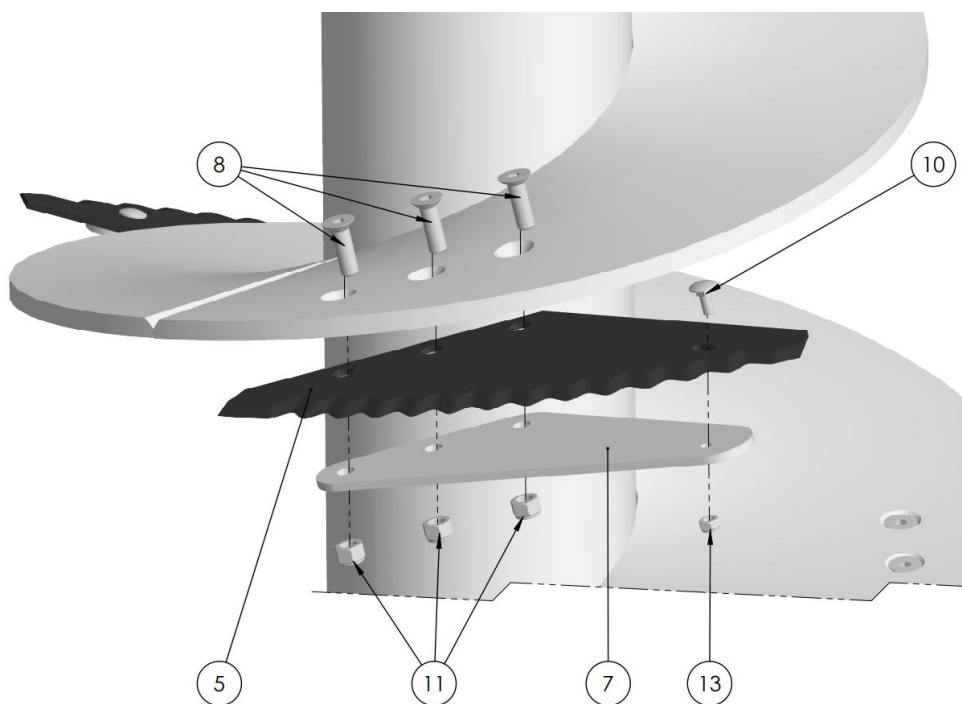
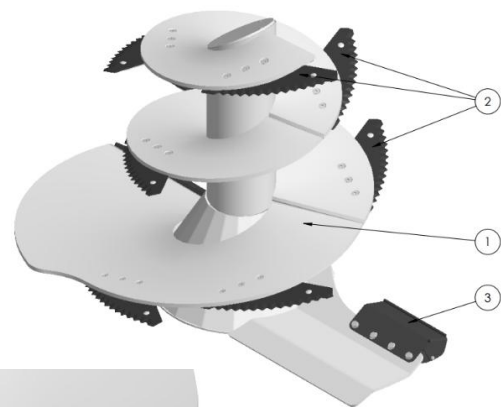

5	Large knife	10	Galvanized steel carriage bolt M10x25 DIN 603 grade 8.8
7	Knife reinforcement	11	Nyloc nut M16 grade 8.8
8	Galvanized hex socket head cap screw M16x50 DIN 7991 grade 10.9	13	Nyloc nut M10 DIN 985 grade 8.8

9.4.2. Auger type 2

Type of grease	Kratos EP3
Service interval	25 operating hours

The auger of this type can be easily removed from the machine for maintenance or repair. This is done by lifting the auger using the lifting eye (4), without the need to disassemble any parts. This allows all work to be performed outside the machine.

The augers are equipped with slide bearings that are lubricated with grease. Greasing is done via lubrication lines, with grease fittings located at the front of the machine. In one location, a grease block is installed containing one or more lubrication points. Always lubricate according to the maintenance schedule.

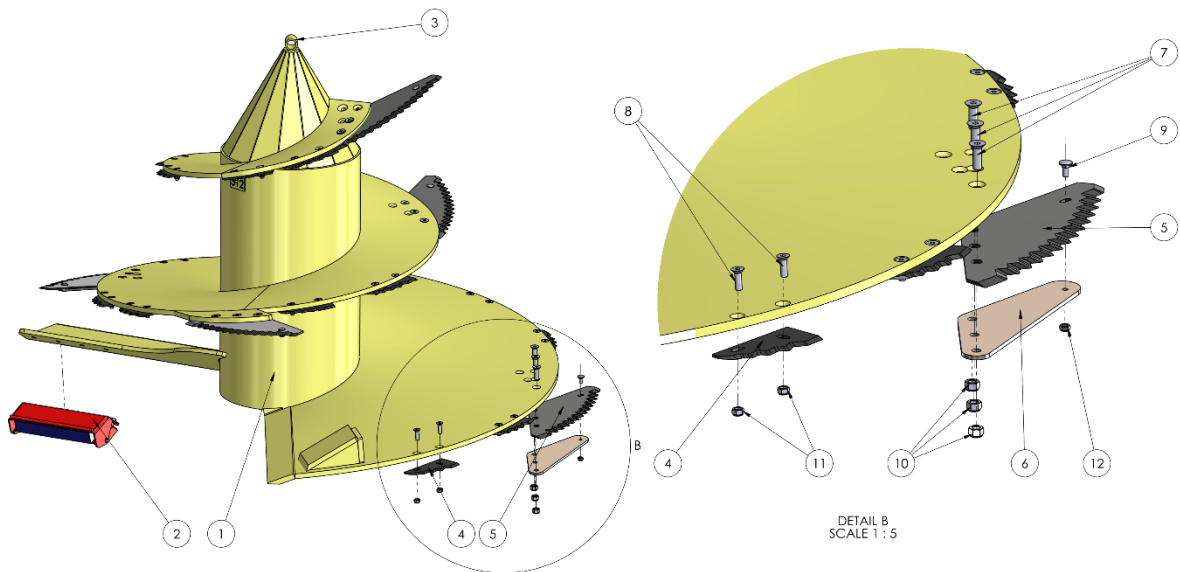
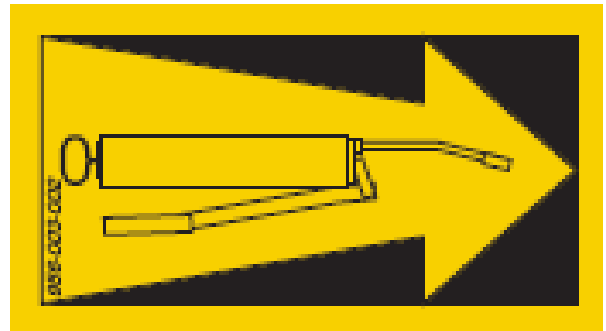

1	Auger construction	7	Hex socket head cap screw M16x50 grade 10.9
2	Auger magnet (option)	8	Hex socket head cap screw M12x40 grade 10.9
3	Lifting eye	9	Galvanized steel carriage bolt M10x25 grade 8.8
4	Small knife	10	Nyloc nut M16 grade 8.8
5	Large knife	11	Nyloc nut M12 grade 8.8
6	Knife reinforcement 8 mm HD 450	12	Galvanized Nyloc nut M10 grade 8.8

9.4.3. Replacing auger knives



CAUTION! Use caution when handling tools or other metal objects near magnets. Keep in mind that when installing or removing auger knives, they will also be attracted by the magnets in the auger, the mixing tub, and the discharge chute.

Sharp knives are essential for achieving good feed mix quality and efficient mixing performance. When the knives are worn, coarse feed is not cut properly, and more power is required, resulting in higher fuel consumption. New auger knives are available from Peeters Landbouwmachines B.V. via <https://peecon.com/contact/>.

9.5. Magnets



CAUTION! Users with pacemakers or other medical devices must keep a safe distance from the machine. Magnetic fields can cause malfunctions or damage to these devices.



CAUTION! Magnetic fields can damage electronics. Keep equipment such as computers, measuring instruments, bank cards, and other electronic components away from the machine.

Optionally, discharge slides can be equipped with magnets to remove any metal particles from the feed mixture at that point as well. In addition, it is possible to install a magnet in the wall of the mixing tub.

If material remains on the magnets, it must be removed to prevent it from re-entering the feed. Always ensure that all safety precautions have been taken before doing this. Then carefully remove all metal parts and debris from the magnets.

9.6. Discharge door

The discharge plates located under the discharge door ensure that the feed is distributed farther away from the machine.

Optionally, these discharge plates can be designed to be movable, linked to the discharge door. In addition, it is possible to equip the discharge plates with magnets.

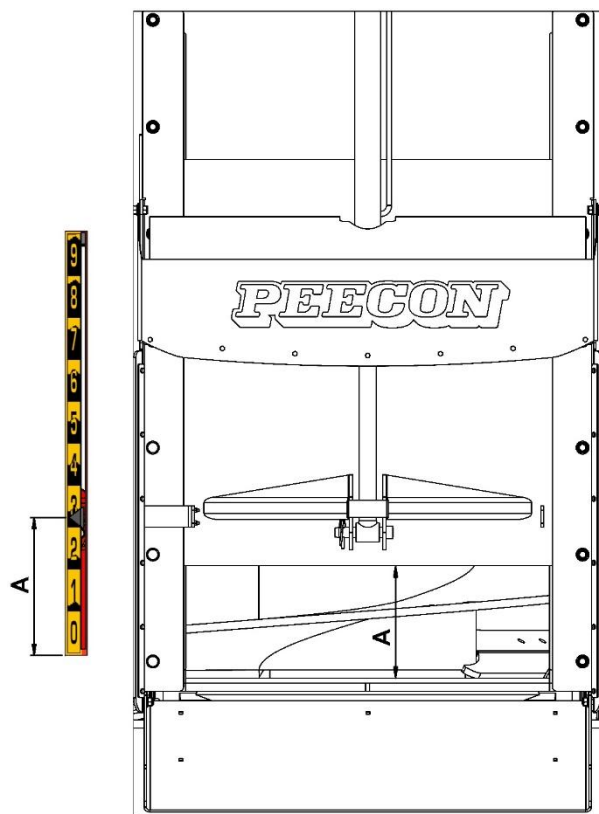

Figure 21 - Discharge door

9.7. Discharge conveyor (option)

9.7.1. Types of discharge conveyors

Machines are available with different types of discharge conveyors. A cross conveyor can be installed at the front or rear of the machine. In addition, the cross conveyor can optionally be designed to slide sideways. Discharge doors can also be equipped with height-adjustable conveyors.

Type of grease	Kratos EP3
Service interval	25 operating hours

Lubrication of the discharge conveyors is performed at the grease fittings on the flange bearings located at the ends of the conveyor. For the hydraulic motor, the bearing is housed in an enclosure, and the grease fitting can be accessed from underneath.

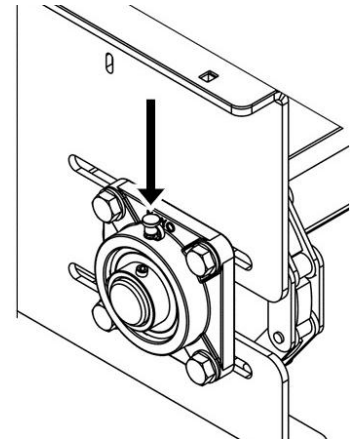

9.7.2. Cleaning the conveyor

Regularly inspect the discharge conveyor for feed residues between the conveyor belt and the rollers, as well as under the belt. Remove any debris and clean the belt regularly to prevent mold formation.

9.7.3. Tensioning the conveyor belt

Check the belt tension regularly and make sure the belt is tracking correctly. After prolonged or intensive use, the belt may stretch. If the tension is insufficient, the belt must be re-tensioned.

To tension the belt, first loosen the bolt connection on the flange bearing (1) so that it can move. Then loosen the locknuts (2). The flange bearing can then be moved outward by tightening the tensioner (3). By moving the flange bearing and roller outward, the belt will become tighter.

Note: Do not set the tension too high, as this will cause excessive wear. Keep in mind that the installation method of the flange bearing and the number of bolt connections may vary depending on the specific conveyor configuration.

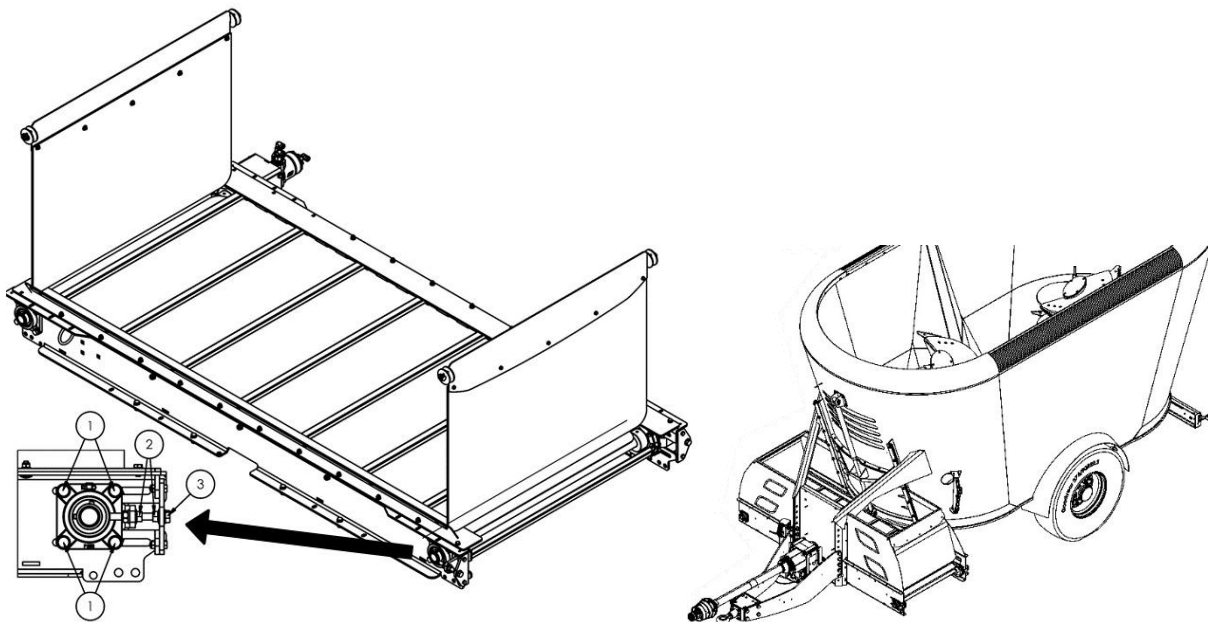

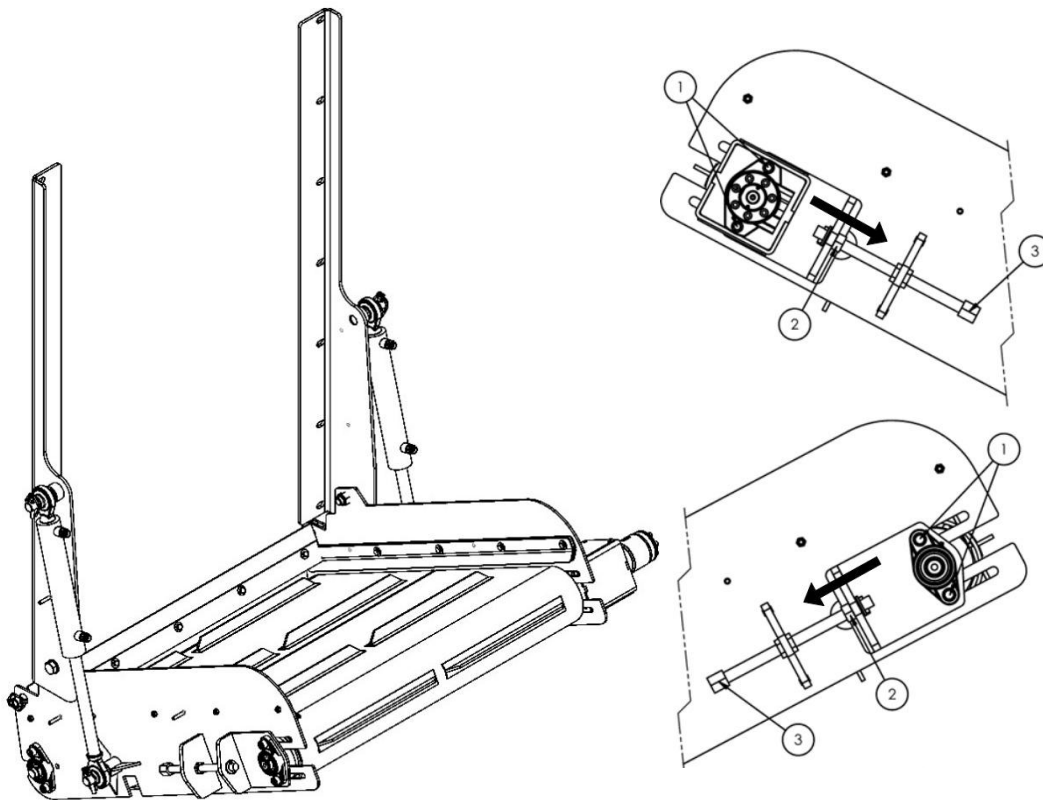

Always check after tensioning to ensure the belt is running centered. If it is not, increase the tension on the side toward which the belt is drifting.

Also check whether the belt is slipping. If the belt slips, the tension is too low or the belt is experiencing excessive resistance, for example due to accumulated feed residues.



CAUTION! Do not overtighten the discharge conveyor belt. This can cause damage to the belt or the rollers and will lead to excessive wear.

9.7.4. Discharge chain

Instead of a conveyor belt, the discharge conveyors can also be equipped with a discharge chain.

9.8. Axles

Depending on the Biga model, your machine is equipped with unbraked axles, hydraulically braked axles, or pneumatically braked axles. For machines with a tridem chassis, the axles can also be designed as steering axles.

Information regarding axle maintenance is provided in the chapters below.



CAUTION! Make sure no lubricant comes into contact with or enters the brakes. This will significantly reduce braking performance. If contamination occurs, thoroughly clean the affected components with appropriate cleaning agents.

9.8.1. Hydraulically braked axles

Lubricate all grease points weekly or at least every 50 operating hours. For hydraulically braked axles, regularly inspect the system for damage or leaks.

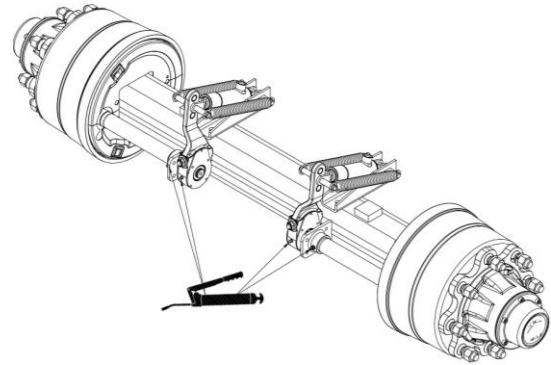

9.8.2. Pneumatically braked axles

Lubricate all grease points weekly or at least every 50 operating hours. For pneumatically braked axles, regularly inspect the system for damage or leaks.

Additionally, periodically drain water from the air tanks using the drain fitting located at the bottom of the tanks.

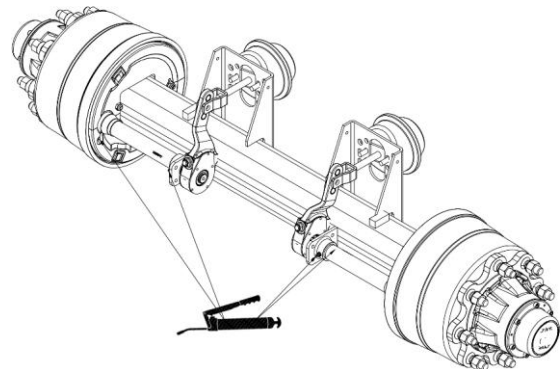

9.8.3. Tandem axles

Lubricate all grease points of the walking beam weekly or at least every 50 operating hours. If applicable, also include the grease points of the previously mentioned braked axles.

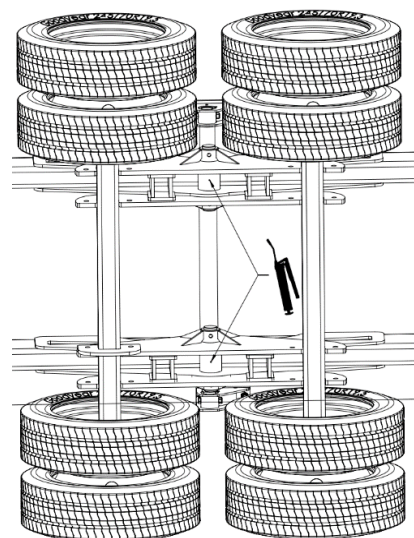

9.8.4. Tridem axles

Lubricate all grease points in the steering assembly and brake assembly weekly or at least every 50 operating hours.

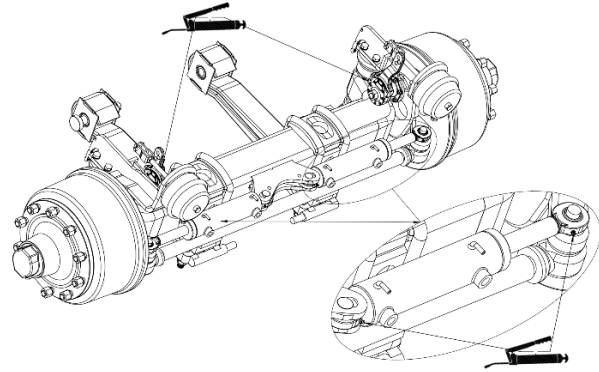

TIP! If the brakes are not operating smoothly, press the brake pedal and slowly tow the machine over a distance of several hundred meters.

9.8.5. Wheel bearings

The condition of the wheel bearings must be checked annually. First, inspect the bearing for any play. If play is detected, the bearing must be readjusted.

Then, apply sufficient fresh grease to the bearing and reinstall the hub cap.

9.9. Hydraulic hoses



CAUTION! Never use your hand to search for a hydraulic leak. Oil under high pressure can penetrate the skin and cause blood poisoning. If this is suspected, seek medical attention immediately.



CAUTION! Always check before starting any work that the hydraulic system is completely depressurized. Dismantling a component that is still under pressure can cause serious injury.

Hydraulic hoses and lines must be inspected at least once per year by a qualified specialist for damage and wear. If any damage or wear is detected, the affected component must be repaired or replaced immediately before the machine is put back into operation.

New hoses must meet the minimum required quality standard: SAE 100 R2A according to DIN 20022/2.

Always avoid contact with pressurized leaking fluids. When working on the hydraulic system, ensure that it is completely depressurized.



9.10. Wheel nuts, chassis bolts and drawbar eyes

After the first 8 operating hours, all bolt connections and wheel nuts must be inspected and tightened to the specified torque.

For dual wheels, make sure that the conical ring is installed in the correct orientation. Incorrect installation can cause the wheel nuts to loosen.

Size	Wrench size (mm)	Tightening torque (Nm)
M8	13	27
M10	17	57
M12	19	101
M14	22	148
M16	24	230
M18	27	348
M20	30	464
M22	32	634
M24	36	798
M27	41	1176
M30	46	1597
M18x1.5 (wheel nut)	27	270
M20x1.5 (wheel nut)	30	350
M22x1.5 (wheel nut)	32	450
M16x2 (drawbar eye)	24	600
M20x2.5 (drawbar eye)	30	600

10. Malfunctions

For more information about malfunctions, you can consult the table below or visit <https://peecon.com/troubleshooting/>.

Malfunction	Cause	Measure/Solution
Shear bolt on PTO shaft breaks	Loading speed too high	Tip bale/block in gradually.
	Machine overloaded	Load the machine up to 90%.
	Restarting mixing process after standstill	Change the loading sequence of the feed components.
	Knives no longer sharp enough	Install sharp knives.
	Incorrect speed	Engage the gearbox in reduction mode.
Feed mix quality insufficient	Loading sequence of feed components	Load coarse feed first (e.g., grass silage).
	Machine overloaded	Load corn component last.
	Method of loading	Load the machine up to 90%.
	Knives no longer sharp enough	Wait to load the next feed component until the first bale has been processed.
	Machine positioned at an angle	Install sharp knives.
	Incorrect auger speed	Place the machine on level ground.
	Counter-knife not extended	Check input speed.
	Too many knives	Run augers between 20 and 30 rpm.
	Feed is not cut sufficiently	Extend the counter-knife.
	Auger knife broken	Knife installed incorrectly
Heavy material tipped onto auger		Check knife sharpness.
Gearbox makes noise	Oil level	Allow the machine to mix longer.
	Gearbox defect	When installing, check that the knife lies flat on the auger and can be mounted without bending.
Lighting does not work	Lamp defective	Tip feed gradually into the machine. Allow time for the knives to process coarse material.
	Cable damaged	Check the oil level and top up if necessary.
No hydraulic function available	Hydraulic hoses connected incorrectly	Connect the hoses correctly.
	Oil supply blocked	Check the line.
	Oil reservoir empty	Refill the reservoir.
	Tractor oil pressure too low	Contact your dealer.
Uneven discharge	Discharge door opened too far	Reduce the opening for more even discharge.
Machine does not mix properly	Adjust the input speed	Reduce the speed by easing off the throttle.
	Change the loading sequence to optimize mixing	Check the loading sequence.
Discharge conveyor does not operate	Oil supply blocked	Check the line.
	Tractor oil reservoir empty	Refill the reservoir.
	Tractor oil pressure too low	Contact your dealer.
	Control slide blocked	Check using manual control.
Shear bolt breaks off	Mixer overloaded	Check why the auger is experiencing excessive resistance.

	Auger blocked	Check why the auger is experiencing excessive resistance.
	PTO engaged too abruptly	Engage the PTO gradually.
Feed is cut too finely	Mixing/cutting time too long	Shorten the mixing/cutting time.
	Counter-knife set too aggressively	Adjust the counter-knife to a less aggressive setting.
One of the functions is not available	Control slide blocked	Check using manual control.
	Oil supply blocked	Check the line.
No functions are available	No power to the controls	Check the power supply.
	Signal cable break	Test the cables.
	Switch no longer works	Replace the switch.
	Fuse defective	Replace the fuse.
Hydraulic valve does not respond	No power to the controls	Check the power supply.
	Signal cable break	Test the cables.
	Electric valve defective	Have the valve replaced.
	Switch no longer works	Replace the switch.

11. System diagrams

11.1. Electrical diagram

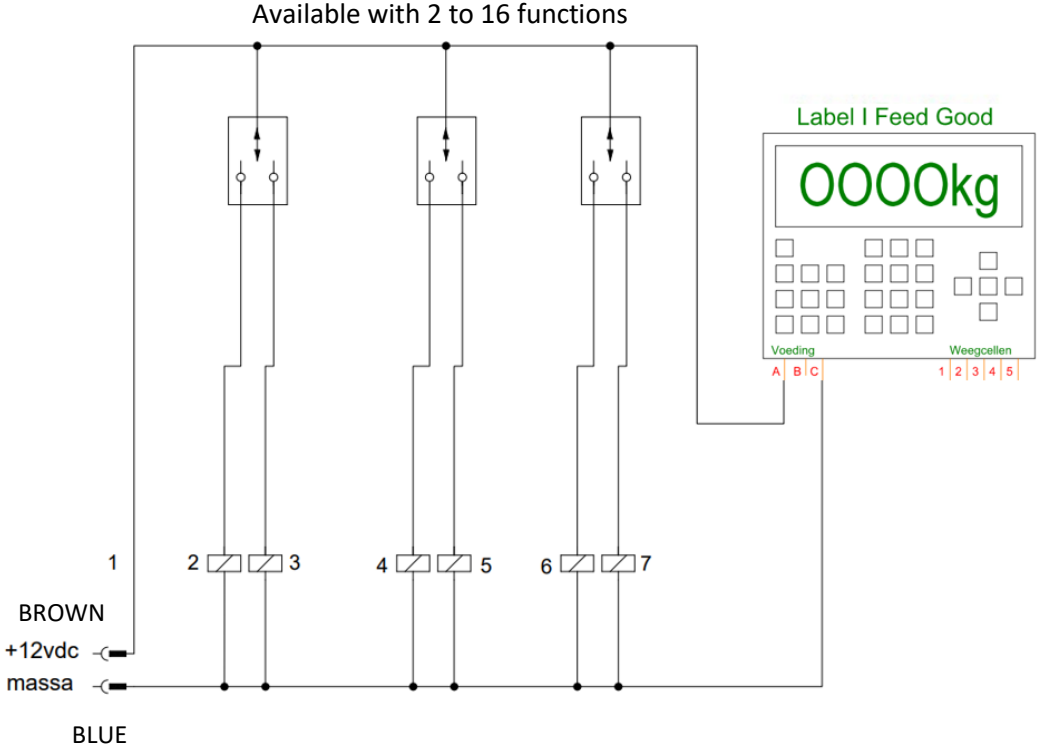

11.2. Hydraulic diagram

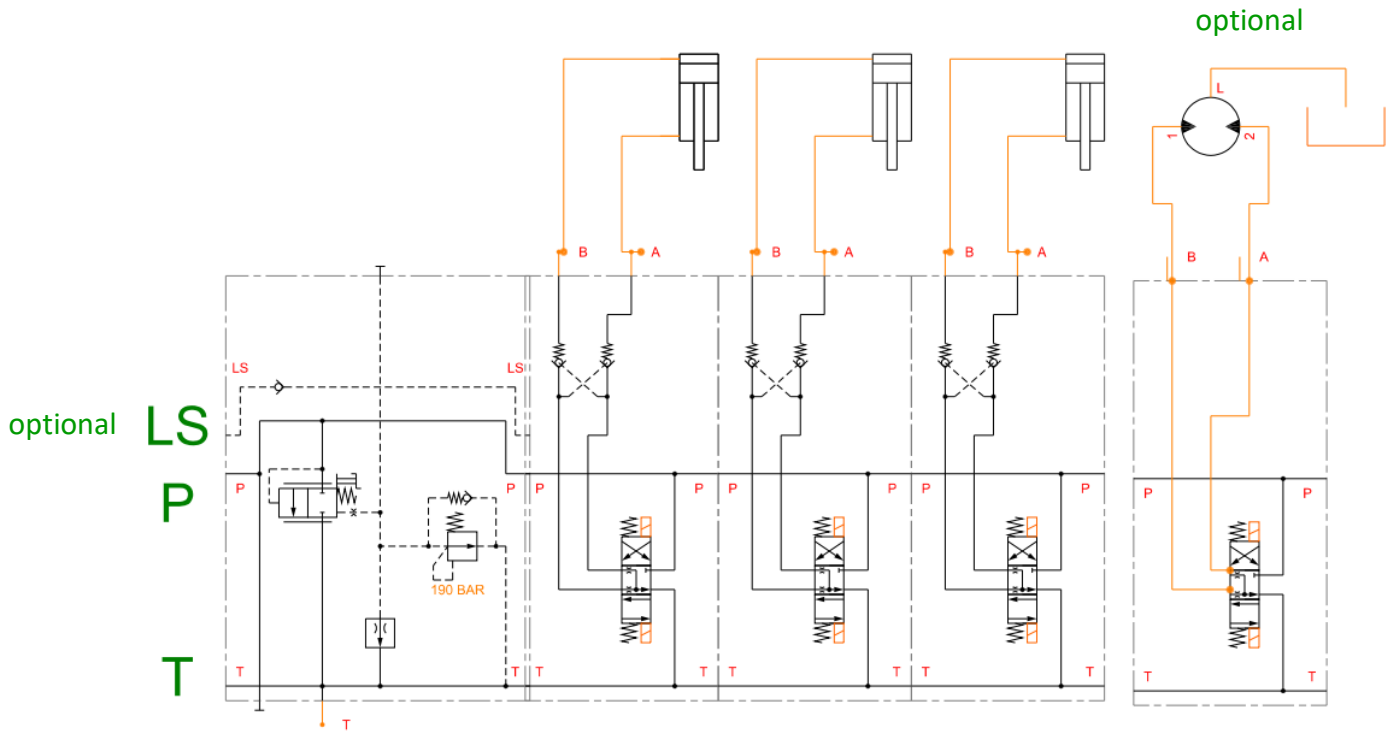

11.3. Weighing system diagram – Biga

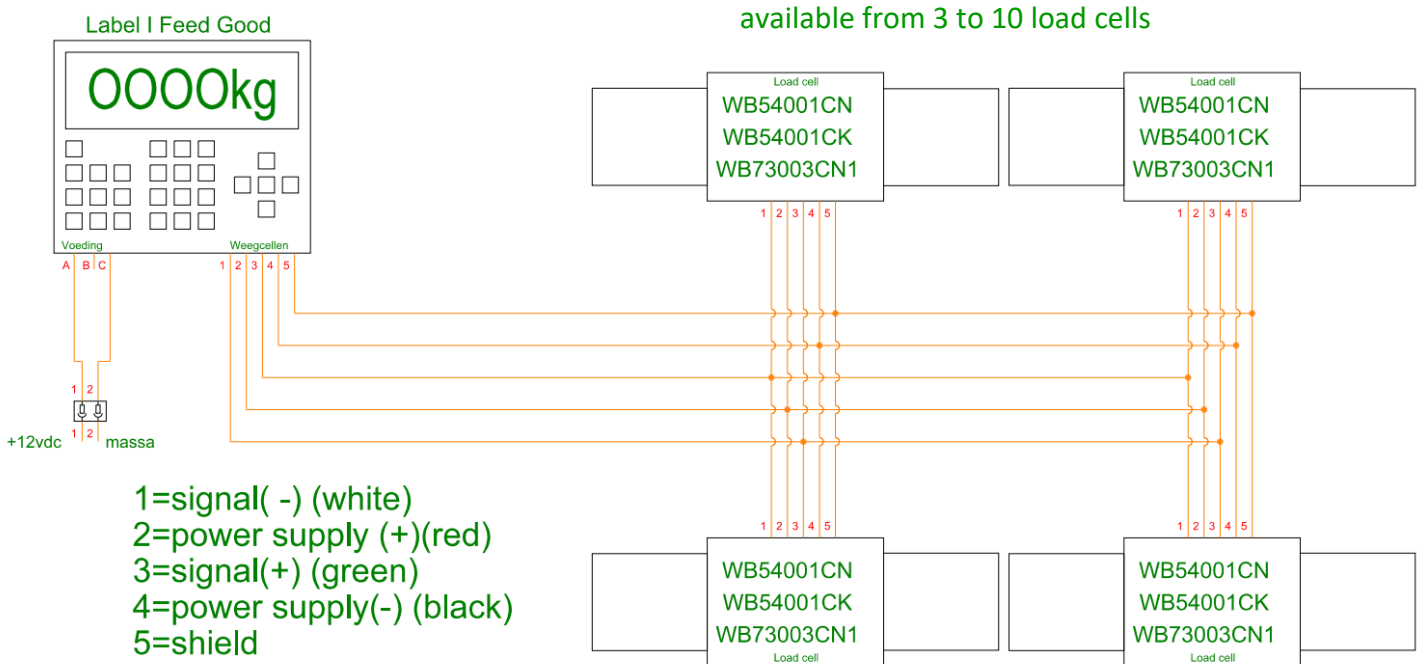

11.4. Weighing system diagram - Biga Topliner

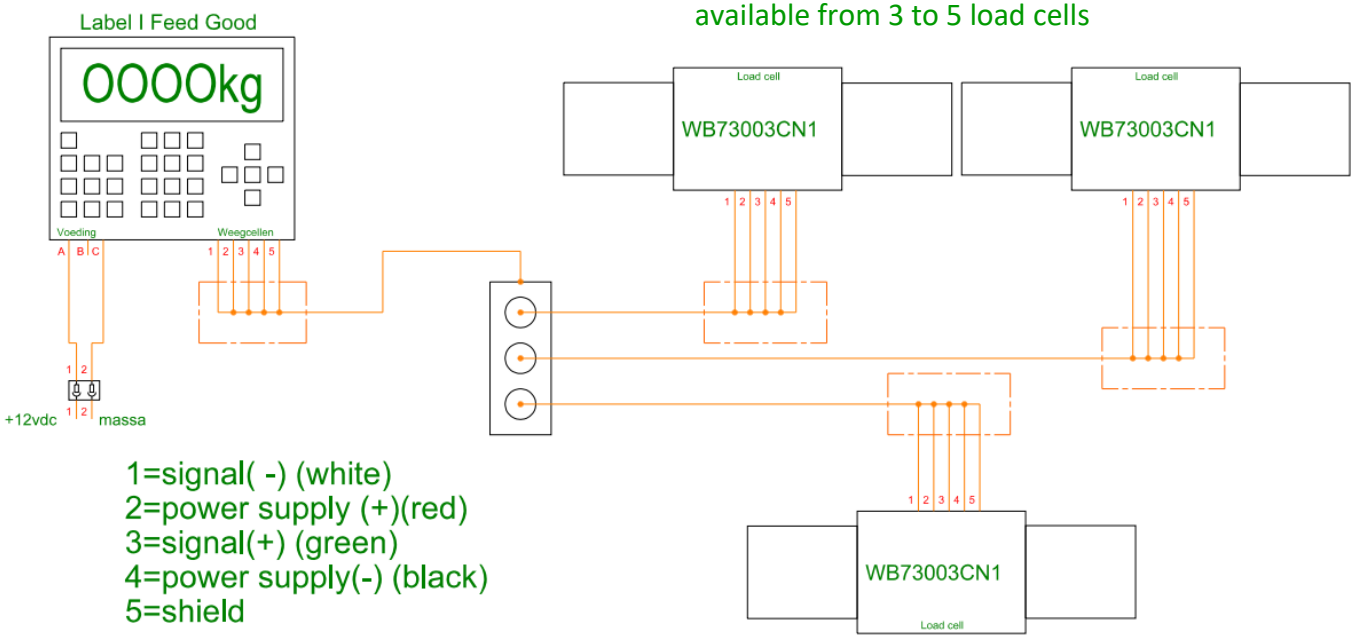

12. Safety Data Sheets liquids

This chapter contains the safety data sheets of the fluids and lubricant that might be present in the machine from factory. The use of these fluids and lubricants is recommended, but it is also possible to use alternative fluids and lubricants, provided they meet the same standards.



WARNING! Never mix different fluids or lubricants unless expressly authorized by the lubricant manufacturer. Mixing lubricants can result in unwanted chemical reactions, causing the machine components to become severely damaged.

1.6. Planetary gearboxes

STANDARD	APPLIED LUBRICANT
ISO VG 220	Q8 El Greco 220 synthetic https://www.q8oils.com/product/q8-el-greco-220/
ISO VG 320	Shell Omala S4 WE 320 https://www.epc.shell.com/DocumentManagement/blobDocumentDownload?DocId=112457452

1.7. General purpose grease

STANDARD	APPLIED GREASE
ISO 6743-09	Texaco Multifak Premium 3 https://cglapps.chevron.com/sdspd/SDSDetailPage.aspx?docDataId=443804&docFormat=PDF